



## User Manual

### Refrigerator-Freezer

HONCQ3T518ENWK

HONCQ3T518ENXK

HONCQ3T518ENTK

HONCQ3T518EWWK

HONCQ3T518EWXK

HONCQ3T518EWTK



<u>4 Safety information</u>	•	<u>Before first use</u>	5
		<u>Installation</u>	5
		<u>Daily use</u>	6
<u>8 Intended use</u>	•		
<u>9 Product description</u>	•		
<u>11 Control panel</u>	•		
<u>12 Use</u>	•	<u>Adjust the temperature for fridge</u>	13
		<u>Adjust the temperature for freezer</u>	13
<u>18 Equipment</u>	•		
<u>20 Energy saving tips</u>	•		
<u>21 Care and cleaning</u>	•		
<u>24 Troubleshooting</u>	•		
<u>28 Installation</u>	•		
<u>32 Technical data</u>	•		
<u>34 Customer service</u>	•		

Thank you for purchasing a Hoover Product.

Please read these instructions carefully before using this appliance. The instructions contain important information which will help you get the best out of the appliance and ensure safe and proper installation, use and maintenance.

Keep this manual in a convenient place so you can always refer to it for the safe and proper use of the appliance.

If you sell the appliance, give it away, or leave it behind when you move house, make sure you also pass this manual so that the new owner can become familiar with the appliance and safety warnings.

## Accessories

Check the accessories and literature with this list:

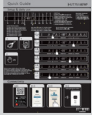

Quik guide



Decorative Energy label covers



Warranty card



User manual

**WARNING – Important Safety information**

---

**NOTICE-General information and tips**

---

**Environmental information**

---

**Disposal**

Help protect the environment and human health. Put the packaging in applicable containers to recycle it. Help to recycle waste of electrical and electronic appliances. Do not dispose appliances marked with this symbol with the household waste. Return the product to your local recycling facility or contact your municipal office.

**WARNING: Risk of fire/flammable material**

The symbol indicates there is a risk of fire since flammable materials are used. Take care to avoid causing a fire by igniting flammable material.

---

**WARNING!**

Risk of injury or suffocation!

Refrigerants and gases must be disposed of professionally. Ensure that the tubing of the refrigerant circuit is not damaged before being properly disposed of. Disconnect the appliance from the mains supply. Cut off the mains cable and dispose of it. Remove the trays and drawers as well as the door catch and seals, to prevent children and pets to get closed in the appliance.

**Before switching on the appliance for the first time read the following safety hints!**



## **WARNING!**

### **Before first use**

- ▶ Make sure there is no transport damage.
- ▶ Remove all packaging and keep out of children's reach.
- ▶ Wait at least two hours before installing the appliance in order to ensure the refrigerant circuit is fully efficient.
- ▶ Handle the appliance always with at least two persons because it is heavy.

### **Installation**

- ▶ The appliance should be placed in a well-ventilated place. Ensure a space of at least 10 cm above and around the appliance.
- ▶ Never place the appliance in a damp area or location where it might be splashed with water. Clean and dry water splashes and stains with a soft clean cloth.
- ▶ Do not install the appliance in direct sunlight or in the near of heat sources (e.g. stoves, heaters).
- ▶ Install and level the appliance in an area suitable for its size and use.
- ▶ Keep ventilation openings in the appliance or in the in-built structure clear of obstruction.
- ▶ Make sure that the electrical information on the rating plate agrees with the power supply. If it does not, contact an electrician.
- ▶ The appliance is operated by a 220-240 VAC/50 Hz power supply. Abnormal voltage fluctuation may cause the appliance to fail to start, or damage to the temperature control or compressor, or there may be an abnormal noise when operating. In such case, an automatic regulator shall be mounted.
- ▶ Do not use multi-plug adapters and extension cables.
- ▶ Do not locate multiple portable socket-outlets or portable power supplies at the rear of the appliance.
- ▶ Ensure that the power cable is not trapped by the refrigerator. Do not step on the power cable.
- ▶ Use a separate earthed socket for the power supply which is easy accessible. The appliance must be earthed.  
Only for UK: The appliance's power cable is fitted with 3-cord (grounding) plug that fits a standard 3-cord (grounded) socket. Never cut off or dismount the third pin (grounding). After the appliance is installed, the plug should be accessible.
- ▶ Do not damage the refrigerant circuit.



## WARNING!

### Daily use

- ▶ This appliance can be used by children aged from 8 years and above and persons with reduced physical, sensory or mental capabilities or lack of experience and knowledge if they have been given supervision or instruction concerning use of the appliance in a safe way and understand the hazards involved.
- ▶ Children aged from 3 to 8 years are allowed to load and unload, but not allowed to clean or install the refrigerating appliances.
- ▶ Keep away children under 3 years of age from the appliance unless they are constantly supervised.
- ▶ Children shall not play with the appliance.
- ▶ If cool gas or other inflammable gas is leaking in the vicinity of the appliance, turn off the valve of the leaking gas, open the doors and windows and do not unplug a plug in the power cable of the refrigerator or any other appliance.
- ▶ Notice that the appliance is set for operation at a specific ambient range between 10 and 43°C. The appliance may not work properly if it is left for a long period at a temperature above or below the indicated range.
- ▶ Do not place unstable articles (heavy objects, containers filled with water) on top of the refrigerator, to avoid personal injury caused by falling or electric shock caused by contact with water.
- ▶ Do not pull on the door shelves. The door may be pulled slant, the bottle rack, may be pulled away, or the appliance may topple.
- ▶ Open and close the doors only with the handles. The gap between the doors and between the doors and the cabinet is very narrow. Do not extend your hands in these areas to avoid pinching your fingers. Open or close the refrigerator doors only when there are no children standing within the range of door movement.
- ▶ Do not store or use inflammable, explosive or corrosive materials in the appliance or in the vicinity.
- ▶ Do not store medicines, bacteria or chemical agents in the appliance. This appliance is a household appliance. It is not recommended to store materials that require strict temperatures.
- ▶ Never store liquids in bottles or cans (besides high percentage spirits) especially carbonated beverages in the freezer, as these will burst during freezing.
- ▶ Check the condition of food if a warming in the freezer has taken place.
- ▶ Do not set unnecessarily low temperature in the refrigerator compartment. Minus temperatures may occur at high settings. Attention: Bottles can burst
- ▶ Do not touch frozen goods with wet hands (wear gloves). Especially do not eat ice lollies immediately after removal from the freezer compartment. There is the risk to freeze or the formation of frost blisters. FIRST aid: keep immediately under running cold water. Do not pull away!
- ▶ Do not touch the inside surface of the freezer storage compartment when in operation, especially with wet hands, as your hands may freeze onto the surface.



## WARNING!

### Daily use

- ▶ Unplug the appliance in the event of a power interruption or before cleaning. Allow at least 7 minutes before restarting the appliance, as frequent starting may damage the compressor.
  - ▶ Do not use electrical devices inside the food storage compartments of the appliance, unless they are of the type recommended by the manufacturer.
- Maintenance / cleaning
- ▶ Make sure children are supervised if they carry out cleaning and maintenance.
  - ▶ Disconnect the appliance from the electrical supply before undertaking any routine maintenance. Allow at least 5 minutes before restarting the appliance, as frequent starting may damage the compressor.
  - ▶ Hold the plug, not the cable, when unplugging the appliance.
  - ▶ Do not clean the appliance with hard brushes, wire brushes, detergent powder, petrol, amyl acetate, acetone and similar organic solutions, acid or alkaline solutions. Please clean with special refrigerator detergent to avoid damage.
  - ▶ Do not scrape off frost and ice with sharp objects. Do not use sprays, electric heaters like heater, hair dryer, steam cleaners or other sources of heat in order to avoid damage to the plastic parts.
  - ▶ Do not use mechanical devices or other means to accelerate the defrosting process, other than those recommended by the manufacturer.
  - ▶ If the supply cord is damaged, it must be replaced by the manufacturer, its service agent or similarly qualified persons in order to avoid a hazard.
  - ▶ Do not try to repair, disassemble or modify the appliance by yourself. In case of repair please contact our customer service.
  - ▶ Eliminate the dust on the back of the unit at least once in the year to avoid hazard by fire, as well as increased energy consumption.
  - ▶ Do not spray or flush the appliance during cleaning.
  - ▶ Do not use water spray or steam to clean the appliance.
  - ▶ Do not clean the cold glass shelves with hot water. Sudden temperature change may cause the glass to break.

### Refrigerant gas information

- ▶ The appliance contains the flammable refrigerant ISOBUTANE (R600a). Make sure the refrigerant circuit is not damaged during transportation or installation. Leaking refrigerant may cause eye injuries or ignite. If a damage has occurred, keep away open fire sources, thoroughly ventilate the room, do not plug or unplug the power cords of the appliance or any other appliance. Inform the customer service.
- ▶ In case of eyes get into contact with the refrigerant, rinse immediately it under running water and call immediately the eye specialist.

### Intended use

This appliance is intended for cooling and freezing food. It has been designed exclusively for use in household and similar applications such as staff kitchen areas in shops, offices and other working environments; farm houses and by clients in hotels, motels and other residential type environments as well as in bed-and-breakfast and catering business. It is not intended for commercial or industrial use. Changes or modifications to the device are not allowed. Unintended use may cause hazards and loss of warranty claims.

### Standards and directives

This product meets the requirements of all applicable EC directives with the corresponding harmonised standards and UK standards, which provide for CE or UKCA marking.

## **i** NOTICE

Due to technical changes and different models, some of the illustrations in this manual may differ from your model.

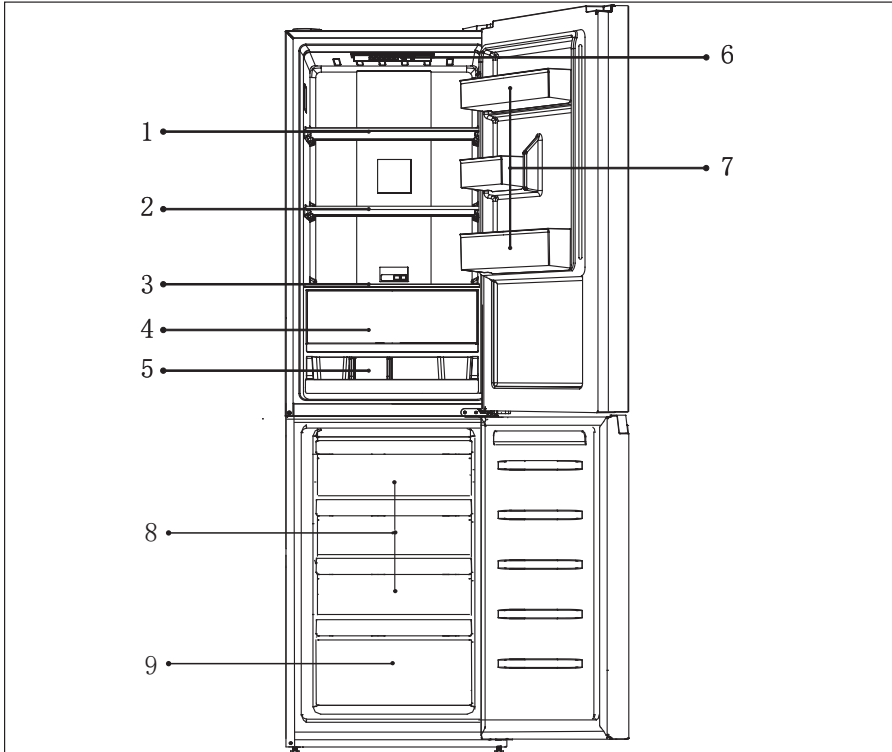

(HONCQ3T518ENWK/HONCQ3T518ENXK/HONCQ3T518ENTK)

A: Refrigerator compartment

B: freezer compartment

1 Glass shelf

8 Upper freezer storage drawer

2 Glass shelf

9 Lower freezer storage drawer

3 Glass shelf

4 Refrigerated drawer

5 Refrigerated tray

6 Display panel

7 Door balcony



## NOTICE

Due to technical changes and different models, some of the illustrations in this manual may differ from your model.

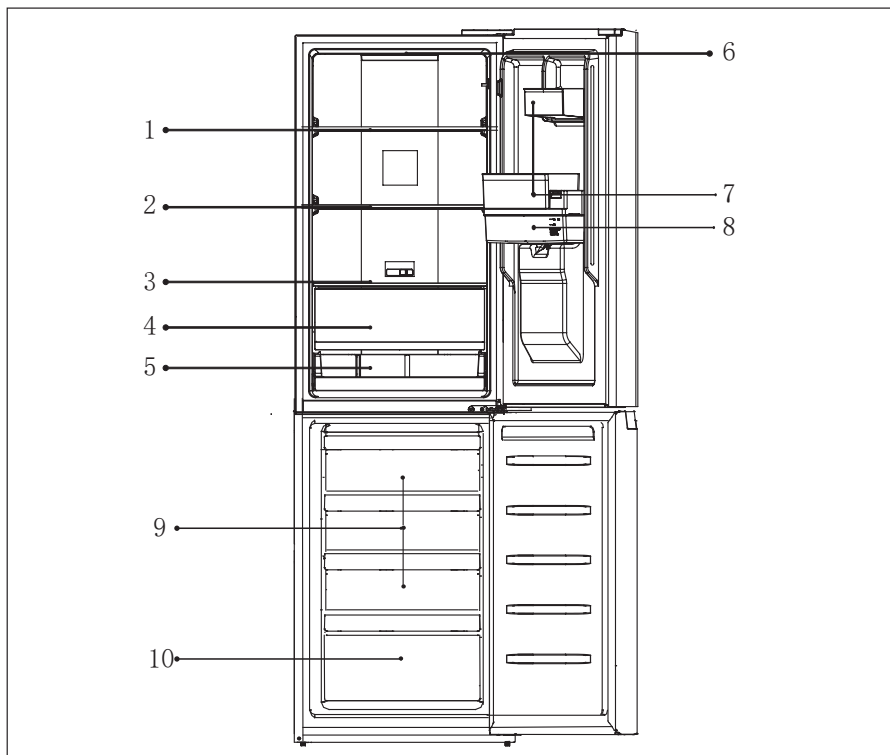

(HONCQ3T518EWWK/HONCQ3T518EWXK/HONCQ3T518EWTK )

A: Refrigerator compartment

B: Freezer compartment

1 Glass shelf

9 Upper freezer storage drawer

2 Glass shelf

10 Lower freezer storage drawer

3 Glass shelf

4 Refrigerated drawer

5 Refrigerated tray

6 Display panel

7 Door balcony

8 Water tank

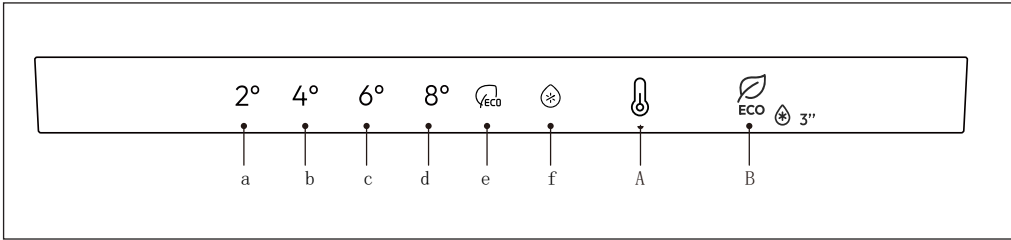

### Keys:

- A Cold storage gear selector : the cold storage gear changes with the cold storage gear
- B ECO/3s Super Cool Function selector: Press to turn on or off the ECO function.  
Press the button for 3 seconds to enter the Super Cool.

### Indicators:

- a/b/c/d Fridge temperature display
- e ECO status display
- f Super Cool status display

### Before first use

- ▶ Remove all packaging materials, keep them out of children`s reach and dispose them in an environmentally friendly manner.
- ▶ Clean the inside and outside of the appliance with water and a mild detergent before putting any food in it.
- ▶ After the appliance has been levelled and cleaned, wait for at least 2-5 hours before connecting it to the power supply. See Section INSTALLATION.
- ▶ Precool the compartments at high settings before loading with food. The function 3S Super Cool helps to cool down the compartments quickly.
- ▶ The refrigerator temperature and freezer temperature are automatically set to 6 gear respectively. These are the recommended settings. If desired, you can change these temperatures manually. Please see ADJUST THE TEMPERATURE.

### Mechanical buttons

The buttons on the display panel are mechanical buttons.

### Switch on /of the appliance

When the refrigerator is connected to the power supply for the first time, the display "C" bright. The default gear of the refrigerator is set to 6 gear.



### NOTICE

The refrigerator temperature and freezer temperature are automatically set to 6 gear respectively. These are the recommended settings. If desired, you can change these temperatures manually.

### Door opening alarm

When the refrigerator door is opened for long time, the door opening alarm will sound to alert the user, and the alarm will be stopped until the refrigerator door is closed.

## Adjust the temperature

The indoor temperatures are influenced by the following factors:

- Ambient temperature
- Frequency of door opening
- Amount of stored foods
- Installation of the appliance

### First powered on

When the refrigerator is initially powered on, the display lights up, the default temperature of the fridge and the freezer is set to 6° gear, and the default temperature of the refrigerated drawer is the fridge compartment setting temperature.

### Adjust the temperature for fridge/freezer

1. Press the button “A” to select the fridge temperature;
2. When pressing once, the buzzer sounds once and the indicator “A” will be bright alternately flashing once from 2° -4° -6° -8° -2° .

2° →4° →6° →8° →2°

3. When the indicator stops flashing, the setting is confirmed.

### ECO function

The ECO model can be activated to optimize the performance of the appliance, where as obtaining the best food storage. If you do not have any special requirements, we recommend that you use ECO Mode function.

1. In the door open state, and the display lights up, click the button ” B” , when the indicator “e” lights on , the refrigerator enters the ECO state.
2. In the ECO state, click the button ” B” , the ECO state will exit manually.



### NOTICE

1. In ECO model can not adjust the gear;
2. The ECO function will automatically exit, when the Super Cool function is enabled the refrigerator is adjusted to a temperature suitable for storing food.

### 3S Super Cool function

1. In the door open state, and the display lights up, long pressing the button "B" for 3 seconds, and the buzzer ring once, the refrigerator enters the "Super Cool" state, and the icon lights up.
2. In the "Super Cool" state, long pressing the button "B" for 3 seconds, after one rings, then manually exit the "Super Cool" state.
3. When the refrigerator reaches the set time, it automatically exits the "3S Super Cool" function.



#### NOTICE

1. In "3S Super Cool" model can not adjust the gear;
2. If you adjust the gear, "3S Super The Cool" icon flashes to indicate that this operation cannot be performed; if you need to adjust, you need to exit "3S Super Cool" function first.



#### NOTICE

If the selector dial is turned to the "Meat" setting, the fridge compartment should be set to 2nd gear, and the storage time should not exceed 24 hours.

### Water dispenser

(Only models with water dispenser) HONCQ3T518EWWK/EWXX/EWTK

With the water dispenser cool drinking water can be tapped.

The water tank should be cleaned before first use (see CARE AND CLEANING).

Filling the water tank



#### WARNING!

Use drinking water only

1. Ensure that the water tank is properly inserted (see EQUIPMENT)
2. Open the square lid (A) and fill the water tank up with fresh drinking water.
3. Fill water only up to the mark (2.0L); as it could overflow when the door opens and closes.
4. Close the square lid until it clicks into place.

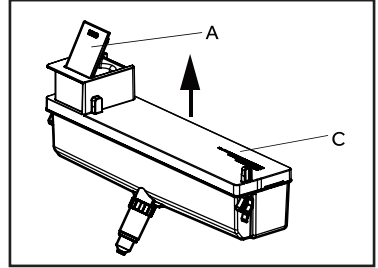

## NOTICE

- Before refilling dispose residual water and clean the water tank.
- When you don't need water for a long time, please empty the water tank and insert the cleaned tank.
- The cover (C) on the water tank is additionally used to save energy. If you don't want to get water from the water dispenser for a long period, please still install the cover because of better insulating and saving energy.

## Getting water from the dispenser

1. Place a glass underneath the water outlet.
2. Push it gently against the water dispenser lever with your glass.

Make sure the glass is in line with the dispenser to prevent the water from splashing out.

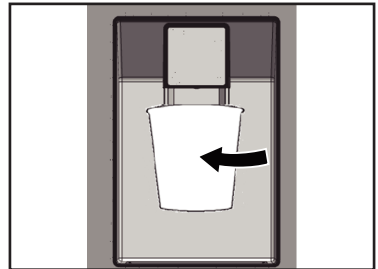

## Tips on storing fresh food

### Storing into the refrigerator compartment

- Keep your fridge temperature below 5°C.
- Hot food must be cooled to room temperature before storing in the appliance.
- Foods stored in the refrigerator should be washed and dried before storing.
- Food to be stored should be properly sealed to avoid odor or taste alterations.
- Do not store excessive quantities of food. Leave spaces between foods to allow cold air flowing around them, for a better and more homogeneous cooling.
- Foods eaten daily should be stored at the front of the shelf.
- Leave a gap between foods and the inner walls, allowing air flowing. In any way, don't store foods against the rear wall: foods could freeze against the rear wall. Avoid direct contact of food (especially oily or acidic food) with the inner liner, as oil/acid can erode the inner liner. Clean away oily/acid dirt whenever it is found.
- Frozen food can be gently defrizzed in the refrigerator compartment. This saves energy.
- The ageing process of fruit and vegetables such as courgettes, melons, papaya, bananas, pineapples, etc. can be accelerated in the refrigerator. Therefore, it is not recommended to store them in the refrigerator. However, the ripening of strongly green fruits can be promoted for a certain period. Onions, garlic, ginger and other root vegetables should also be stored at room temperature.
- Unpleasant odours inside the fridge are a sign that something has spilled and cleaning is required. See Care And Cleaning.
- Different foods should be placed in different areas according to their properties.

### Storage into the freezer compartment

- Keep the freezer temperature at -18°C.
- Hot food must be cooled to room temperature before storing in the freezer compartment.
- Food cut into small portions will freeze faster and be easier to defrost and cook. The recommended weight for each portion is less than 2.5 kg
- It is better to pack food before putting it into the freezer. The outside of the packaging must be dry to avoid bags sticking together. Packaging materials should be odour-free, airtight, non-poisonous and nontoxic.
- In order to avoid expiration of storage periods, please note the freezing date, time limit and name of the food on the packaging according to the storage periods of different foods.



## WARNING!

- Acid, alkali and salt etc. could erode the internal surface of the freezer.
- Do not place the food with these substances (e.g. sea fish) directly on the internal surface. Salt water in the freezer should be cleaned up immediately.
- Do not exceed the food storage time recommended by the manufacturers. Only take the required amount of food out of the freezer.
- Consume defrosted food quickly. Defrosted food cannot be re-frozen unless it is first cooked, otherwise it may be less edible.
- Do not load excessive quantities of fresh food in the freezer compartment. Refer to the freezing capacity of the freezer - See TECHNICAL DATA or data at the type plate.
- Food can be stored in the freezer at a temperature of at least  $-18^{\circ}\text{C}$  for 2 to 12 months, depending on its properties (e.g. meat: 3-12 months, vegetables: 6-12 months)
- While freezing fresh food, avoid bringing them in contact with already frozen food. Risk of thawing.

### **When storing commercially frozen foods, please follow these guidelines:**

- Always follow manufacturers' guidelines for the length of time you should store food for. Do not exceed these guidelines!
- Try to keep the length of time between purchase and storage as short as possible to preserve food quality.
- Buy frozen food, which have been stored at a temperature of  $-18^{\circ}\text{C}$  or below.
- Avoid buying food which has ice or frost on the packaging - This indicates that the products might have been partially defrosted and refrozen at some point temperature rising affects the quality of food.

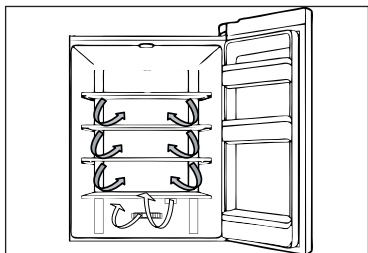

### Multi-air-flow

The refrigerator is equipped with a multi-air-flow system, with which cool air flows are located on every shelf level. This helps to maintain a uniform temperature to ensure that your food is kept fresher for longer.

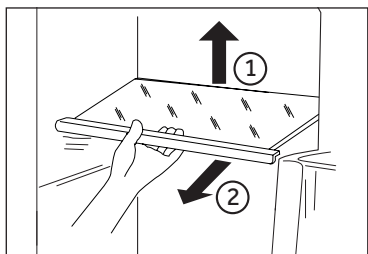

### Adjustable shelves

1. The height of the shelves can be adjusted to fit your storage needs.
2. To relocate a shelf, remove it first by uplifting its hind edge ① and pulling it out ②.
3. To reinstall it, put it on the lugs on both sides and push it to the most rearward position until the rear of the shelf is fixed inside the slots in the sides.

### **i** NOTICE

Ensure that all ends of a shelf are level.

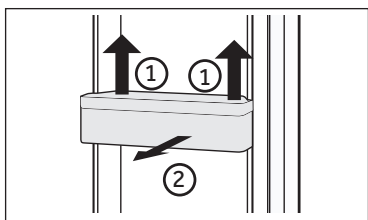

### Removable door racks/bottle holder

1. The door racks can be removed for cleaning:
2. Place hands on each side of the rack, lift it upwards ① and pull it out ②.
3. In order to insert the door rack, the above steps are carried out in reverse order.

### **i** NOTICE

When the appliance is switched on, it may take up to 12 hours for the correct temperatures to be reached.

## Removable drawer

To remove the drawer out, pull out to the maximum extent ①, lift and remove ②

In order to insert the drawer, the above steps are carried out in reverse order.

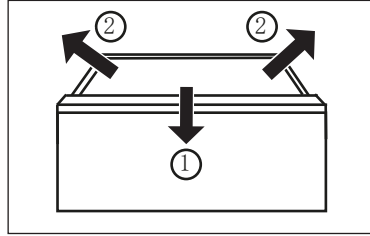

## The Light

The LED interior light comes on when the door is opened. The performance of the lights is not affected by any of the appliances other settings.

## Removable water tank

(Only models with water dispenser )  
HONCQ3T518EWWK/EWXXK/EWTK

The water tank can be removed and reinstalled for cleaning in the same way as door shelves.

### Insert water tank

(Only models with water dispenser )  
HONCQ3T518EWWK/EWXXK/EWTK

Place the water tank in the position that the water outlet(B) fits into the opening of the door. Make sure that the water tank is locked.

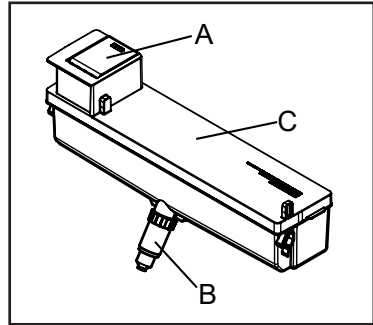



## Energy saving tips

- ▶ Make sure the appliance is properly ventilated (see INSTALLATION).
- ▶ Do not install the appliance in direct sunlight or in the near of heat sources (e.g. stoves, heaters).
- ▶ Avoid unnecessarily low temperature in the appliance. The energy consumption increases the lower the temperature in the appliance is set.
- ▶ Functions like POWER- FREEZE consume more energy.
- ▶ Allow warm food to cool down before placing it in the appliance.
- ▶ Open the appliance door as little and as briefly as possible.
- ▶ Do not overfill the appliance to avoid obstructing the air flow.
- ▶ Avoid air within the food packaging.
- ▶ Keep door seals clean so that the door always closes correctly.
- ▶ Defreeze frozen food in the fridge storage compartment.
- ▶ The most energy-saving configuration requires the appliance keep drawers, food box and shelves on factory-fresh condition, and food should be places as far as possible without blocking the air outlet of the duct.



## WARNING!

Disconnect the appliance from the power supply before cleaning.

### Cleaning

1. Clean the appliance when only little or no food is stored.
2. The appliance should be cleaned every four weeks for good maintenance and to prevent bad stored food odors.



## WARNING!

- ▶ Do not clean the appliance with hard brushes, wire brushes, detergent powder, petrol, amyl acetate, acetone and similar organic solutions, acid or alkaline solutions. Please clean with special refrigerator detergent to avoid damage.
- ▶ Do not spray or flush the appliance during cleaning.
- ▶ Do not use water spray or steam to clean the appliance.
- ▶ Do not clean the cold glass shelves with hot water. Sudden temperature change may cause the glass to break .
- ▶ Do not touch the inside surface of the freezer storage compartment, especially with wet hands, as your hands may freeze onto the surface.
- ▶ In case of heating check the condition of frozen goods.

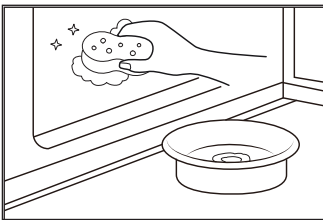

- ▶ Always keep the door gasket clean.
- ▶ Clean the inside and housing of the appliance with a sponge dampened in warm water and neutral detergent.
  1. Please scrub the interior and exterior of the refrigerator, including door sealing, door rack, glass shelves, boxes and so on, with a soft towel or sponge dipped in warm water (you may add neutral detergent into the warm water).
- ▶ 2. If there is liquid spilled, remove all the contaminated parts, directly rinse with the flow water, dry and place it back into the fridge.
- ▶ 3. If there is spilled cream (such as the cream, melting ice cream), please remove all the contaminated parts, put into the warm water with about 40 °C for some time, then rinse with the flow water, dry and place it back into the fridge.
- ▶ 4. In case some small part or component gets stuck inside of the fridge (between shelves or drawers), use small soft brush to release it. If you could not reach the part, please contact Haier service
- ▶ Rinse and dry with soft cloth.
- ▶ Do not clean any of the parts of the appliance in a dishwasher.
- ▶ Allow at least 5 minutes before restarting the appliance as frequent starting may damage the compressor.

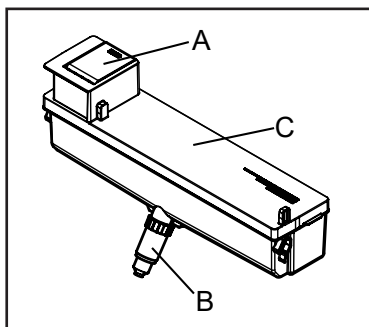

### Cleaning the water tank (Only models with water dispenser) HONCQ3T518EWWK/EWXK/EWTK

1. Take off the water tank out of the appliance.
2. Remove the cover (C).
3. Unscrew the dispenser cock (B).
4. Clean the tank and dispenser cock with warm water and liquid dishwashing detergent. Make all soap is rinsed off.
5. Mount the dispenser cock, close the cover and replace the tank inside the appliance.

### Defrosting

The defrosting of the refrigerator and the freezer compartment are done automatically; no manual operation is needed.

## Replacing the LED-lamps



### WARNING!

Do not replace the LED lamp yourself, it must only be replaced by either the manufacturer or the authorised service agent.

The lamps adopts LED as its light source, featuring low energy consumption and long service life. If there is any abnormality, please contact the customer service. See CUSTOMER SERVICE.

Parameters of the lamps:

Refrigerator compartment: 12 V max 2.3 W

## Non-use for a longer period

If the appliance is not used for an extended period of time, and you will not use the Holiday-function for the refrigerator:

Take out the food.

Unplug the power cord.

Clean the appliance as described above.

Keep the doors open to prevent the creation of bad odours inside.



### NOTICE

Turn the appliance off only if strictly necessary.

## Moving the appliance

1. Remove all food and unplug the appliance.
2. Secure shelves and other moveable parts in the fridge and the freezer with adhesive tape.
3. Do not tilt the refrigerator more than 45° to avoid damaging the refrigerating system.



### WARNING!

- ▶ Do not lift the appliance by its handles.
- ▶ Never place the appliance horizontally on the ground.

Many occurring problems could be solved by yourself without specific expertise. In case of a problem please check all shown possibilities and follow below instructions before you contact an after sales service. See CUSTOMER SERVICE.



## WARNING!

- ▶ Before maintenance, deactivate the appliance and disconnect the mains plug from the mains socket.
- ▶ Electrical equipment should be serviced only by qualified electrical experts, because improper repairs can cause considerable consequential damages.
- ▶ A damaged supply should only be replaced by the manufacturer, its service agent or similarly qualified persons in order to avoid a hazard.

Problem	Possible Cause	Possible Solution
The compressor does not work.	<ul style="list-style-type: none"> <li>• Mains plug is not connected in the mains socket.</li> <li>• The appliance is in the defrosting cycle</li> </ul>	<ul style="list-style-type: none"> <li>• Connect the mains plug.</li> <li>• This is normal for an automatic defrosting</li> </ul>
The appliance runs frequently or runs for a too long period of time.	<ul style="list-style-type: none"> <li>• The indoor or outdoor temperature is too high.</li> <li>• The appliance has been off power for a period of time.</li> <li>• A door of the appliance is not tightly closed.</li> <li>• The door has been opened too frequently or for too long.</li> <li>• The temperature setting for the freezer compartment is too low.</li> <li>• The door gasket is dirty, worn, cracked or mismatched.</li> <li>• The required air circulation is not guaranteed.</li> </ul>	<ul style="list-style-type: none"> <li>• In this case, it is normal for the appliance to run longer.</li> <li>• Normally, it takes 8 to 12 hours for the appliance to cool down completely.</li> <li>• Close the door/drawer and ensure the appliance is located on a level ground and there is no food or container jarring the door.</li> <li>• Do not open the door/drawer too frequently.</li> <li>• Set the temperature higher until a satisfactory refrigerator temperature is obtained. It takes 24 hours for the refrigerator temperature to become stable.</li> <li>• Clean the door/drawer gasket or replace them by the customer service.</li> <li>• Ensure adequate ventilation.</li> </ul>
The inside of the refrigerator is dirty and/or smells.	<ul style="list-style-type: none"> <li>• The inside of the refrigerator needs cleaning.</li> <li>• Food of strong odour is stored in the refrigerator.</li> </ul>	<ul style="list-style-type: none"> <li>• Clean the inside of the refrigerator.</li> <li>• Wrap the food thoroughly..</li> </ul>

Problem	Possible Cause	Possible Solution
<p>It is not cold enough inside the appliance.</p>	<ul style="list-style-type: none"> <li>• The temperature is set too high.</li> <li>• Too warm goods has been stored.</li> <li>• Too much food has been stored at one time.</li> <li>• The goods are too close to each other.</li> <li>• A door/drawer of the appliance is not tightly closed.</li> <li>• The door/drawer has been opened too frequently or for too long.</li> </ul>	<ul style="list-style-type: none"> <li>• Reset the temperature.</li> <li>• Always cool down goods before storing them.</li> <li>• Always store small quantities of food.</li> <li>• Leave a gap between several foods allowing air flowing.</li> <li>• Close the door/drawer.</li> <li>• Do not open the door/drawer too frequently.</li> </ul>
<p>It is too cold inside the appliance.</p>	<ul style="list-style-type: none"> <li>• The temperature is set too low.</li> <li>• The Super-Frz/Super-Coolfunction is activated or is running too long.</li> </ul>	<ul style="list-style-type: none"> <li>• Reset the temperature.</li> <li>• Switch off the Super-Frz/Super-Cool function</li> </ul>
<p>Moisture formation on the inside of the refrigerator compartment.</p>	<ul style="list-style-type: none"> <li>• The climate is too warm and toodamp.</li> <li>• A door/drawer of the appliance is not tightly closed.</li> <li>• The door/drawer has been opened too frequently or for too long.</li> <li>• Food containers or liquids are left open.</li> </ul>	<ul style="list-style-type: none"> <li>• Increase the temperature.</li> <li>• Close the door/drawer.</li> <li>• Do not open the door/drawer too frequently.</li> <li>• Let hot foods cool to room temperature and cover foods and liquids.</li> </ul>
<p>Moisture accumulates on the refrigerators outside surface or between the doors/door and drawer.</p>	<ul style="list-style-type: none"> <li>• The climate is too warm and too damp.</li> <li>• The door is not closed tightly. The cold air in the appliance and the warm air outside it condensates.</li> </ul>	<ul style="list-style-type: none"> <li>• This is normal in damp climate and will change when the humidity decreases.</li> <li>• Ensure that he door/drawer is tightly shut.</li> </ul>

Problem	Possible Cause	Possible Solution
Strong ice and frost in the freezer compartment.	<ul style="list-style-type: none"> <li>• The goods were not adequately packaged .</li> <li>• A door/drawer of the appliance is not tightly closed.</li> <li>• The door/drawer has been opened too frequently or for too long.</li> <li>• The door/drawer gasket is dirty, worn, cracked or mismatched.</li> <li>• Something on the inside prevents the door/drawer to close properly.</li> </ul>	<ul style="list-style-type: none"> <li>• Always pack the goods well.</li> <li>• Close the door/drawer.</li> <li>• Do not open the door/drawer too frequently.</li> <li>• Clean the door/drawer gasket or replace them by new ones.</li> <li>• Reposition the shelves, door racks, or internal containers to allow the door/drawer to close.</li> </ul>
The sides of the cabinet and door strip get warm.		<ul style="list-style-type: none"> <li>• This is normal.</li> </ul>
The appliance makes abnormal sounds.	<ul style="list-style-type: none"> <li>• The appliance is not located on level ground.</li> <li>• The appliance touches some object around it.</li> </ul>	<ul style="list-style-type: none"> <li>• Adjust the feet to level the appliance.</li> <li>• Remove objects around the appliance.</li> </ul>
A slight sound is to be heard similar to that of flowing water.		<ul style="list-style-type: none"> <li>• This is normal.</li> </ul>
You will hear an alarm beep.	<ul style="list-style-type: none"> <li>• The fridge storage compartment door is open.</li> </ul>	<ul style="list-style-type: none"> <li>• Close the door.</li> </ul>
You will hear a faint hum.	<ul style="list-style-type: none"> <li>• The anti-condensation system is working</li> </ul>	<ul style="list-style-type: none"> <li>• This prevents condensation and is normal</li> </ul>
The interior lighting or cooling system does not work.	<ul style="list-style-type: none"> <li>• Mains plug is not connected in the mains socket.</li> <li>• The power supply is not intact.</li> <li>• The LED-lamp is out of order.</li> </ul>	<ul style="list-style-type: none"> <li>• Connect the mains plug.</li> <li>• Check the electrical supply to the room. Call the local electricity company!</li> <li>• Please call the service for changing the lamp.</li> </ul>

Problem	Possible Cause	Possible Solution
Water leaking or dripping from the water dispenser spout.	<ul style="list-style-type: none"> <li>• The water tank is not installed correctly</li> <li>• The water dispenser spout is not screwed tight to the tank.</li> <li>• The white silicon O ring is missing from the water spout.</li> </ul>	<ul style="list-style-type: none"> <li>• Refit the water tank into the fridge door, ensure it is pushed fully into the door.</li> <li>• The water spout is screwed in firmly to the water tank.</li> <li>• Check the water spout has a white silicon O ring at the tank end before fitting the water spout to the water tank.</li> </ul>

To contact the technical assistance, visit our website: <https://corporate.haier-europe.com/en/>

Under the section "website", choose the brand of your product and your country. You will be redirected to the specific website where you can find the telephone number and form to contact the technical assistance.

### Power interruption

In the event of a power cut, food should remain safely cold for about 5 hours. Follow these tips during a prolonged power interruption, especially in summer:

- ▶ Open the door/drawer as few times as possible.
- ▶ Do not put additional food into the appliance during a power interruption.
- ▶ If prior notice of a power interruption is given and the interruption duration is longer than 5 hours, make some ice and put it in a container in the top of the refrigerator compartment.
- ▶ An inspection of the goods is required immediately after the interruption.
- ▶ As temperature in the refrigerator will rise during a power interruption or other failure, the storage period and edible quality of food will be reduced. Any food that defrosts should be either consumed, or cooked and refrozen (where suitable) soon afterwards in order to prevent health risks.

### Memory function during power interruption

After restoration of power the appliance continues with the settings that were set before the power failure.

## Unpacking

**WARNING!**

The appliance is heavy. Always handle with at least two persons. Keep all packaging materials out of children's reach and dispose them in an environmentally friendly manner.

Take the appliance out of the packaging.

Remove all packaging materials.

## Environmental conditions

The room temperature should always be between 10° C and 43° C, since it can influence the temperature inside the appliance and its energy consumption. Do not install the appliance near other heat-emitting appliances (ovens, refrigerators) without isolation.

## Space recommendation

Recommended space when door is opened (Fig. 1.2.)

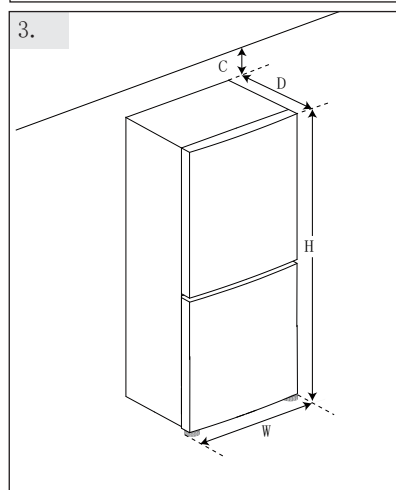
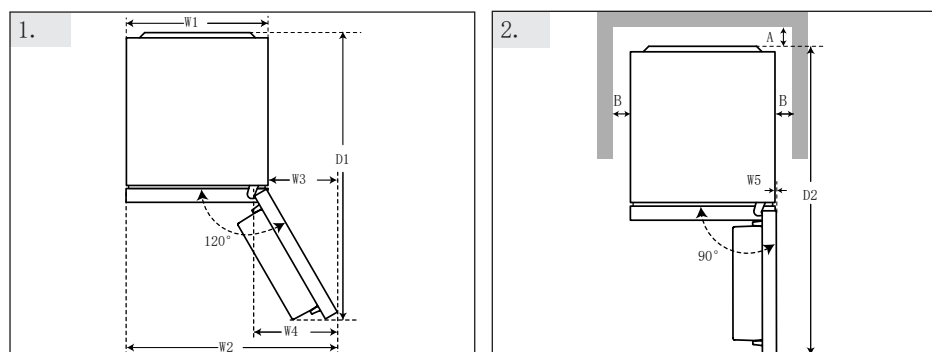

(Unit : mm)		Model
Width	W1	545
	W2	835
	W3	290
	W4	318
	W5	13
	W	545
Depth	D1	1070
	D2	1135
	D	100
Distance to back wall	A	100
Distance to lateral walls	B	100
Distance to ceiling	C	100
Overall Height	H	1850

## Ventilaton cross-section

To achieve sufficient ventilation of the appliance for safety reasons, the information of the required ventilation cross sections must be observed .

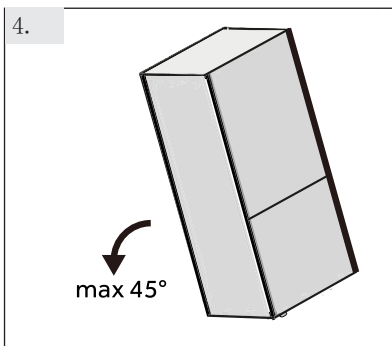

Aligning the appliance (Fig.4.5.6). The appliance should be placed on a flat and solid surface.

4. Tilt the refrigerator slightly backwards.

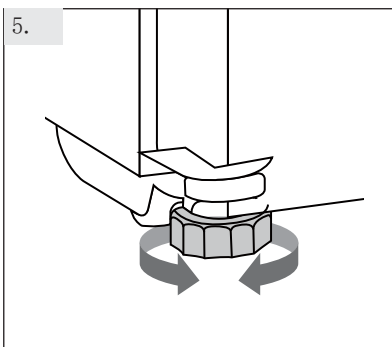

5. Set the feet to the desired level.

Make sure the distance to the wall on the hinge side is at least 100 mm for the door to open properly.

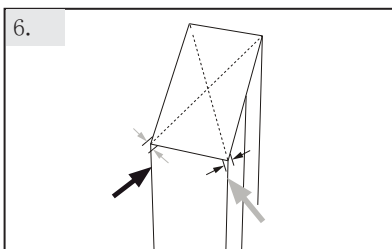

6. The stability can be checked by alternately bumping on the diagonals. The slightly swaying should be the same in both directions. Otherwise the frame can warp; possible leaking door seals are the result. A low tendency to the rear facilitates the closing of the doors.



### NOTICE

For a free standing appliance: this refrigerating appliance is not intended to be used as a built-in appliance

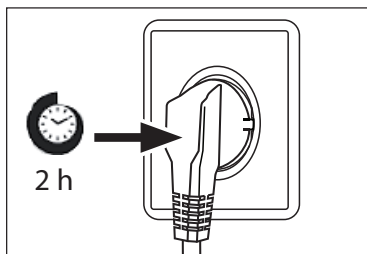

### Waiting time

To the maintenance-free lubrication oil is located in the capsule of the compressor. This oil can get through the closed pipe system during slanting transport. Before connecting the appliance to the power supply you have to wait at least 2 hours so that the oil runs back into the capsule.

### Electrical connection

Before each connection check if:

- ▶ power supply, socket and fusing are appropriate to the rating plate.
- ▶ the power socket is earthed and no multi-plug or extension.
- ▶ the power plug and socket are strictly according.

Connect the plug to a properly installed household socket.



### WARNING!

To avoid risks a damaged power cord must be replaced by the customer service (see warranty card).



### WARNING!

For a free standing appliance: this refrigerating appliance is not intended to be used as a built-in appliance

## Door Reversibility

Before connecting the appliance to the power supply, you should check whether the door swing must be changed from right (as delivered) to left, if this is required by the installation location and the usability.



### WARNING!

- The appliance is heavy. You need two persons to carry out the door reversibility.
- Before any operation, first unplug the appliance from the mains.
- Do not tilt the appliance more than 45°C to prevent damage of the refrigeration system.

## Assembly steps

1. Provide necessary tool.
  2. Unplug the appliance.
  3. Remove the upper hinge cover 1 and unscrew the upper hinge (three screws) on right side 2.
  4. Unplug the connection cable
  5. Lift the loose refrigerator door carefully off the middle hinge.
  6. Remove the middle hinge.
  7. Remove the small cover of the front panel from left to right side.
  8. Turn the door upside down and unscrew the cover (1). Take out the new cover (2) from the necessary bag and screw them to opposite side.
  9. Change the positions of the blanking plugs and the screw on the side.
  10. Screw the middle hinge to the left side of the appliance. Pay attention to inverting the pivot of the middle hinge, ensuring that the side with the gasket is facing upwards
  11. Lift the upper door carefully on the middle hinge. And be sure the pivot fits into the hinge barrel of the lower door.
  12. Take out the new upper hinge and hinge cover from the accessory bag. Put the connection cable through the upper hinge and fix the upper hinge with three screws on left side of appliance. And the put the hinge cover over the hinge.
  13. Plug in the connection cable.
  14. Replace front panel and fix it with five screws.
- After the change of the door, check if the door seals are located properly on the housing and all screws are tightened well.

Product fiche according to regulation EU No. 2019/2016

Brand	Hoover	Hoover
Model name / identifier	HONCQ3T518ENWK HONCQ3T518ENXK HONCQ3T518ENTK	HONCQ3T518EWWK HONCQ3T518EWXK HONCQ3T518EWTk
Category of the model	Refrigerator-freezer	Refrigerator-freezer
Energy efficiency class	E	E
Annual energy consumption(kWh/year)(1)	244	243
Total volume(L)	306	303
Volume refrigerator(L)	196	193
Volume freezer(L)	110	110
Volume chiller section(L)	/	/
Volume auto ice maker(L)	/	/
Star rating	4	4
Defrosting type	Auto-defrost	Auto-defrost
Freezing capacity(kg/24h)	5	5
Climate rating(2)	SN-N-ST-T	SN-N-ST-T
Noise emission class and air – borne acoustical noise emissions(db(A) re 1pW)	B (35)	B (35)
Temperature rise time (h)	9	9
Type of appliance	freestanding	freestanding

Explanations:

- Yes, featured

- (1) Based on the results of the standards conformance test over 24 hours. The actual consumption depends on the use and the location of the appliance.
- (2) Climate rating SN: This appliance is intended for use in an ambient temperature of between + 10°C and +32°C

Climate rating N: This appliance is intended for use in an ambient temperature of between + 16°C and +32°C

Climate rating ST: This appliance is intended for use in an ambient temperature of between + 16°C and +38°C

Climate rating T: This appliance is intended for use in an ambient temperature of between + 16°C and +43°C

Additional technical data

Voltage / Frequency	220-240V ~/ 50Hz
Input current (A)	1.5
Main fuse (A)	16
Coolant	R600a(46g)
Dimensions (H/W/D in mm)	1850 / 545/ 622

We recommend our Haier Customer Service and the use of original spare parts. If you have a problem with your appliance, please first check section TROUBLE-SHOOTING.

If you cannot find a solution there, please contact

- ▶ your local dealer or
- ▶ our European Call Service-Center (see listed phone numbers below) or
- ▶ the Service & Support area at [www.haier.com](http://www.haier.com) where you can activate the service claim and also find FAQs.

To contact our Service, ensure that you have the following data available. The information can be found on the rating plate.

Model \_\_\_\_\_

Serial No. \_\_\_\_\_

Also check the Warranty Card supplied with the product in case of warranty.

European Call Service-Center		
Country*	Phone number	Costs
Haier Italy (IT)	199 100 912	
Haier Spain (ES)	902 509 123	
Haier Germany (DE)	0180 5 39 39 99	<ul style="list-style-type: none"> <li>• 14 Ct/Min Landline</li> <li>• max 42 Ct/Min Mobile</li> </ul>
Haier Austria (AT)	0820 001 205	<ul style="list-style-type: none"> <li>• 14,53 Ct/Min Landline</li> <li>• max 20 Ct/Min all others</li> </ul>
Haier United Kingdom (UK)	0333 003 8122	
Haier France (FR)	0980 406 409	

\* For other countries please refer to [www.haier.com](http://www.haier.com)

Haier Europe Trading S.r.l

Branch UK

Westgate House, Westgate, Ealing

London, W5 1YY

\*Duration of the guarantee of the refrigerating appliance:

Minimum guarantee is: 2 years for EU Countries, 3 years for Turkey, 1 year for UK, 1 year for Russia, 3 years for Sweden, 2 years for Serbia, 5 years for Norway, 1 year for Morocco, 6 months for Algeria, Tunisia no legal warranty required.

\*The period of spare parts for the repair of the appliance:

Thermostats, temperature sensors, printed circuit boards and light sources are available for a minimum period of seven years after placing the last unit of the model on the market.

Door handles, door hinges, trays and baskets for a minimum period of seven years and door gaskets for a minimum period of 10 year, after placing the last unit of the model on the market.

\*For further information about the product, please consult <https://eprel.ec.europa.eu/> or scan the QR on the energy label supplied with the appliance.



***HOOVER***