



BUILT-IN GAS OVENS

INSTALLATION ADVICES - INSTRUCTIONS FOR THE USE

GB

- FCG962DX SASO
- FCG962DN SASO

Dear Customer,

Thank you for having purchased and given your preference to our product. The safety precautions and recommendations within this booklet are for your own safety and that of others. They will also provide a means by which to make full use of the features offered by your appliance.

Please preserve this booklet carefully. It may be useful in future, either to yourself or to others in the event that doubts should arise relating to its operation.

This appliance must be used only for the task it has explicitly been designed for, that is for cooking foodstuffs. Any other form of usage is to be considered as inappropriate and therefore dangerous.

The manufacturer declines all responsibility in the event of damage caused by improper, incorrect or illogical use of the appliance.

IMPORTANT SAFETY PRECAUTIONS AND RECOMMENDATIONS

IMPORTANT: This appliance is designed and manufactured solely for the cooking of domestic (household) food and is not suitable for any non domestic application and therefore should not be used in a commercial environment.

The appliance guarantee will be void if the appliance is used within a non domestic environment i.e. a semi commercial, commercial or communal environment.

Read the instructions carefully before installing and using the appliance.

- This appliance has been designed and manufactured in compliance with the applicable standards for the household cooking products, including those for surface temperatures. Some people with sensitive skin may have a more pronounced temperature perception with some components although these parts are within the limits allowed by the norms. The complete safety of the appliance also depends on the correct use, we therefore recommend to always pay a extreme attention while using the product, especially in the presence of children.
- After having unpacked the appliance, check to ensure that it is not damaged and that the oven door closes correctly. In case of doubt, do not use it and consult your supplier or a professionally qualified technician.
- Packing elements (i.e. plastic bags, polystyrene foam, nails, packing straps, etc.) should not be left around within easy reach of children, as these may cause serious injuries.
- Some appliances are supplied with a protective film on steel and aluminium parts. **This film must be removed before using the appliance.**
- **IMPORTANT:** The use of suitable protective clothing/gloves is recommended when handling or cleaning this appliance.
- Do not attempt to modify the technical characteristics of the appliance as this may become dangerous to use. The manufacturer declines all responsibility for any inconvenience resulting from the inobservance of this condition.

- CAUTION: this appliance must only be installed in a permanently ventilated room in compliance with the applicable regulations.
- Do not operate your appliance by means of an external timer or separate remote-control system.
- Do not carry out cleaning or maintenance operations on the appliance without having previously disconnected it from the electric power supply.
- WARNING: Ensure that the appliance is switched off before replacing the oven lamp to avoid the possibility of electric shock.
- Do not use a steam cleaner because the moisture can get into the appliance therefore making it unsafe.
- Do not touch the appliance with wet or damp hands (or feet).
- Do not use the appliance whilst in bare feet.
- If you should decide not to use this appliance any longer (or decide to substitute another model), before disposing of it, it is recommended that it be made inoperative in an appropriate manner in accordance to health and environmental protection regulations, ensuring in particular that all potentially hazardous parts be made harmless, especially in relation to children who could play with unused appliances.
- The various components of the appliance are recyclable. Dispose of them in accordance with the regulations in force in your country. If the appliance is to be scrapped, remove the power cord.
- After use, ensure that the knobs are in the off position.
- Children less than 8 years of age shall be kept away unless continuously supervised.
- This appliance can be used by children aged from 8 years and above and persons with reduced physical, sensory or mental capabilities or lack of experience and knowledge if they have been given supervision or instruction concerning use of the appliance in a safe way and understand the hazards involved. Children shall not play with the appliance. Cleaning and user maintenance shall not be made by children without supervision.
- The manufacturer declines all liability for injury to persons or damage to property caused by incorrect or improper use of the appliance.

- **WARNING:** During use the appliance and its accessible parts become hot; they remain hot for some time after use.
 - Care should be taken to avoid touching heating elements inside the oven.
 - The door is hot, use the handle.
 - To avoid burns and scalds, young children should be kept away.
- Make sure that electrical cables connecting other appliances in the proximity of the oven cannot become entrapped in the oven door.
- **WARNING:** When correctly installed, your product meets all safety requirements laid down for this type of product category. However special care should be taken around the rear or the underneath of the appliance as these areas are not designed or intended to be touched and may contain sharp or rough edges, that may cause injury.
- **FIRST USE OF THE OVEN** - it is advised to follow these instructions:
 - Furnish the interior of the oven as described in the chapter “CLEANING AND MAINTENANCE”.
 - Switch on the empty oven on max to eliminate grease from the heating elements.
 - Disconnect the appliance from the electrical power supply, let the oven cool down and clean the interior of the oven with a cloth soaked in water and neutral detergent; then dry carefully.
- **CAUTION:** Do not use harsh abrasive cleaners or sharp metal scrapers to clean the oven door glass since they can scratch the surface, which may result in shattering of the glass.
- Do not line the oven walls or floor with aluminium foil. Do not place baking trays or the drip tray on the base of the oven chamber.
- **FIRE RISK!** Do not store flammable material in the oven.
- Always use oven gloves when removing the shelves and food trays from the oven whilst hot.
- Do not hang towels, dishcloths or other items on the appliance or its handle – as this could be a fire hazard.

- Clean the oven regularly and do not allow fat or oils to build up in the oven base or tray. Remove spillages as soon as they occur.
- Do not stand on the open oven door.
- Always stand back from the appliance when opening the oven door to allow steam and hot air to escape before removing the food.
- **SAFE FOOD HANDLING:** Leave food in the oven for as short a time as possible before and after cooking. This is to avoid contamination by organisms which may cause food poisoning. Take particular care during warmer weather.
- **WARNING:** Take care NOT to lift the appliance by the door handle.
- The appliance must not be installed behind a decorative door in order to avoid overheating.
- The oven accessories (e.g. oven wire rack) must be fitted correctly as indicated at page 42.
- **IMPORTANT NOTE:** The oven shelves (for some products one shelf only is provided) have not been designed to place the food directly on the shelf itself. When cooking, always place the food in special containers or use specific materials suitable for the food contact.
- If the power supply cable is damaged, it must be replaced only by an authorized service agent in order to avoid a hazard.
- If the appliance is not fitted with a supply cord and a plug, or with other means for disconnection from the supply mains having a contact separation in all poles that provide full disconnection under overvoltage category III conditions, means for disconnection must be incorporated in the fixed wiring in accordance with the wiring rules.
- **WARNING:** The appliance and its accessible parts become hot during use.
Care should be taken to avoid touching heating elements.
Children less than 8 years of age shall be kept away unless continuously supervised.

ADVICE
for the
INSTALLER

1 INSTALLATION

IMPORTANT

- The appliance is designed and approved for domestic use only and should not be installed in a commercial, semi commercial or communal environment.
Your product will not be guaranteed if installed in any of the above environments and could affect any third party or public liability insurances you may have.
- This appliance is to be installed only by an authorised person according to the current local regulations and in observation of the manufacturer's instructions.
- Failure to comply with this condition will render the guarantee invalid.
- Incorrect installation, for which the manufacturer accepts no responsibility, may cause personal injury or damage.
- This appliance shall only be serviced by authorized personnel.
- The oven can be fitted in standard units, width 90 cm and depth 60 cm.
- Installation requires a compartment as illustrated in figures 1.1a and 1.1b.
- On the lower side, the oven must lay on supports standing the oven weight.
- Some appliances are supplied with a protective film on steel and aluminium parts. This film must be removed before using the appliances.
- **Important: The use of suitable protective clothing/gloves is recommended when handling or installing this appliance.**
- **The walls adjacent to the oven must be of material resistant to heat.**
- **We would point out that the adhesive which bonds the plastic laminate to the furniture must withstand temperatures not less than 150°C to avoid delamination.**
- **The walls of the unit must be capable of resisting temperatures of 70°C above room temperature.**
- **Do not instal the appliance near inflammable materials (eg. curtains).**
- **Under no circumstances should any external covers be removed for servicing or maintenance except by suitably qualified personnel.**
- **Do not seal the oven into the cabinetry with silicone or glue; this makes future servicing difficult. The manufacturer will not cover the costs of removing the oven, or of damage caused by this removal.**
- **Caution: Do not lift this oven by the door handle.**

WARNING

When correctly installed, your product meets all safety requirements laid down for this type of product category.

However special care should be taken around the rear or the underneath of the appliance as these areas are not designed or intended to be touched and may contain sharp or rough edges, that may cause injury.

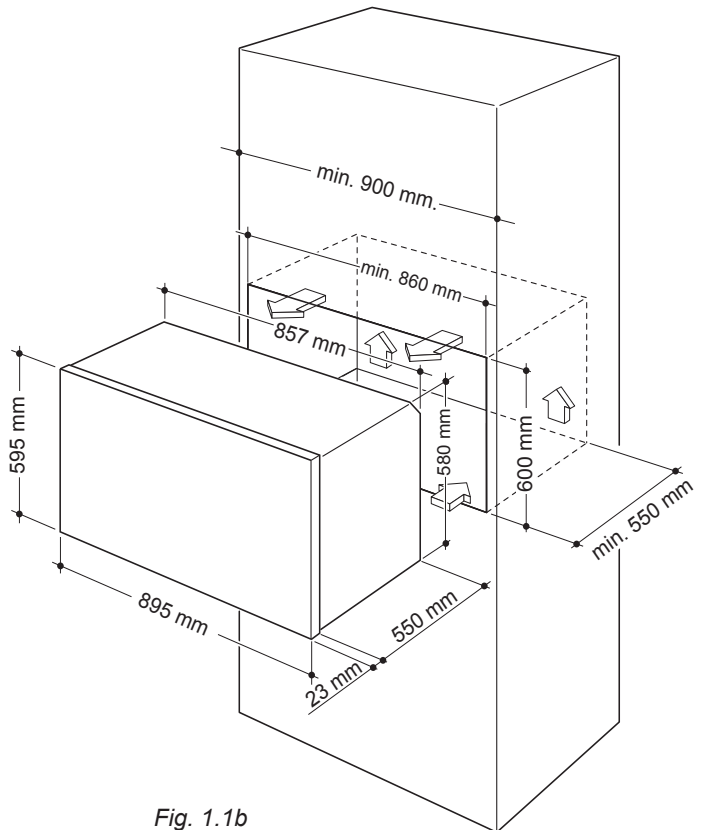
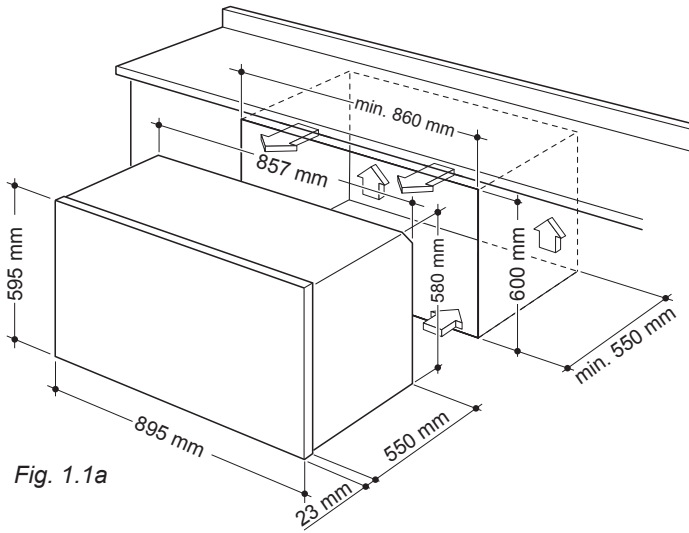

FIXING THE OVEN

Introduce the oven into the furniture opening and fix it with 4 screws (not supplied) as figure 1.2. It is essential that the oven rests on a surface which will support its weight, as the screw fixing is only complementary.

Adjust the hinges of furniture doors adjacent to the oven to allow a 4-5 mm gap between the furniture door and the oven frame.

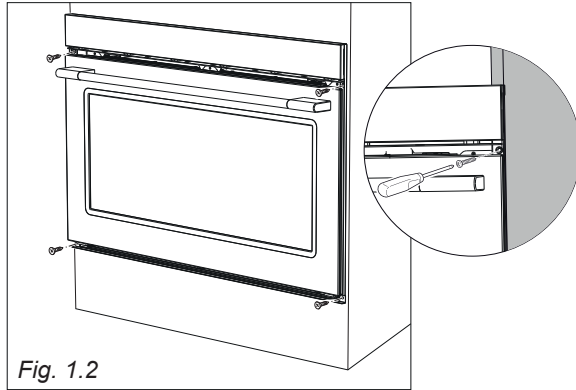

Fig. 1.2

IMPORTANT:

To avoid damage to the lower trim please note the following instructions.

The lower trim is designed to allow for good air circulation and the correct opening of the oven door.

To ensure the trim is not damaged due to the appliance being placed on the floor, the appliance should be suitably supported as in illustration here below.

After installation the appliance door should be slowly opened to ensure no damage has occurred.

No responsibility for lower trim damage will be accepted if these instructions have not been followed.

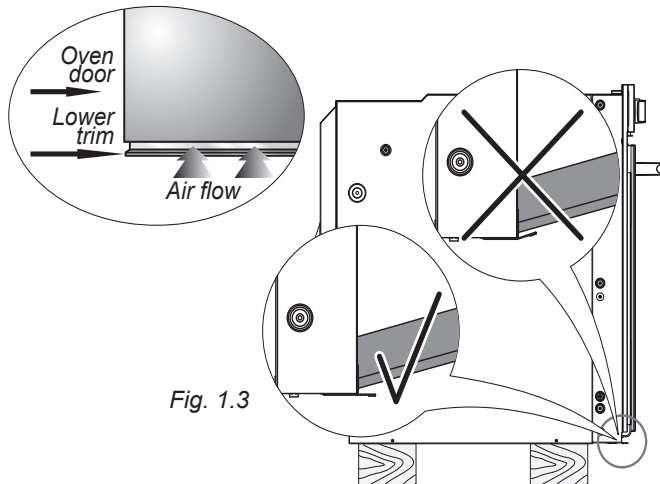

Fig. 1.3

VENTILATION REQUIREMENTS

The appliance must be installed in compliance with applicable local regulations concerning ventilation and the evacuation of exhaust gases.

Intensive and prolonged use may require extra ventilation, e.g. opening a window, or more efficient ventilation increasing the mechanical suction power if this is fitted.

CHOOSING SUITABLE SURROUNDINGS

The room where the gas appliance is to be installed must have a natural flow of air so that the gas can burn (in compliance with applicable local regulations).

The flow of air must come directly from one or more openings made in the outside walls with a free area of at least 100 cm² (or refer to applicable local regulations).

The openings should be near the floor and preferably on the side opposite the exhaust for combustion products and must be made so that they cannot be blocked from either the inside or the outside.

When these openings cannot be made, the necessary air can come from an adjacent room which is ventilated as required, as long as it is not a bed room or a danger area (in compliance with applicable local regulations).

In this case, the kitchen door must allow the passage of the air.

DISCHARGING PRODUCTS OF COMBUSTION

Extractor hoods connected directly to the outside must be provided, to allow the products of combustion of the gas appliance to be discharged (fig. 1.4).

If this is not possible, an electric fan may be used, attached to the external wall or the window; the fan should have a capacity to circulate air at an hourly rate of 3-5 times the total volume of the kitchen (fig.1.5).

The fan can only be installed if the room has suitable vents to allow air to enter, as described under the heading "Choosing suitable surroundings".

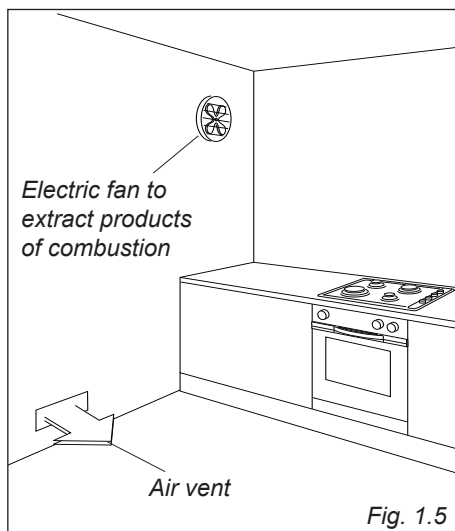
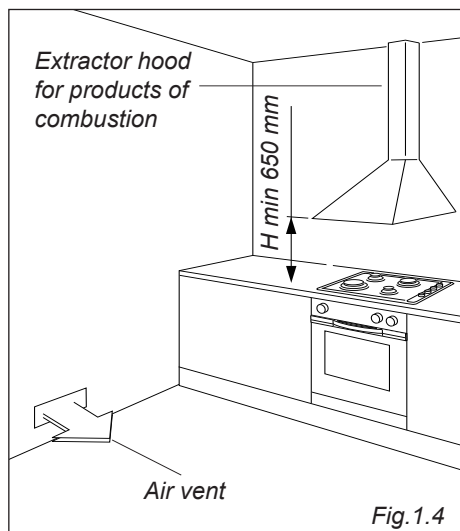

GAS INSTALLATION REQUIREMENTS

Important !

- This appliance must be installed and serviced only by a suitably qualified, registered installer. The installer shall refer to the local standards in force.
- Failure to install the appliance correctly could invalidate any manufacturer's warranty.
- Before installation, make sure that the local distribution conditions (gas type and pressure) and the adjustment of this appliance are compatible. The appliance adjustment conditions are given on the plate or the label.
- If the gas pressure (for which the appliance is to be used) is variable or if it is not within the values indicated on the rating plate, it is mandatory to install a proper gas pressure regulator which must be adjusted to guarantee the correct operating pressure to the appliance (as per rating plate).
The regulator must be installed, adjusted and tested by a qualified technician.
- **WARNING:** Using the appliance with a wrong and/or variable gas pressure may be extremely dangerous and may result in serious injury to the user. Damage to the appliance could occur if not observing this condition.
The manufacturer declines every responsibility for any inconvenience resulting from the inobservance of this condition.

This appliance is supplied for use on LPG (PROPANE/BUTANE, 5 kPa; check the gas regulation label attached on the appliance).

CONNECTING TO THE GAS SUPPLY

The gas connection fitting (fig. 2.2) is made up of:

- the floating nut;
- the gasket/s;

The gas connection must be carried out by an authorised person according to the relevant local standards.

- If using a flexible hose, make sure it does not come into contact with moving parts.
- The supplied gaskets guarantee a good seal for the gas connection. We recommend that you replace the gaskets on the slightest sign of wear, deformation or imperfection.
- **After connecting to the gas mains, check that the couplings are correctly sealed, using soapy solution, but never a naked flame.**

DETAILS FOR CONNECTING TO THE GAS SUPPLY

The components described in the fig. 2.2 shall be fixed as indicated in the fig. 2.3.

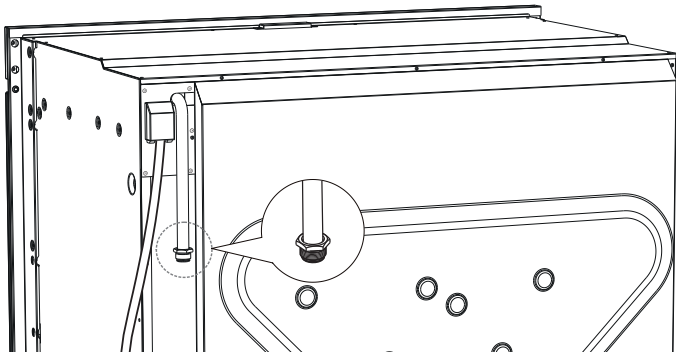

Fig. 2.1

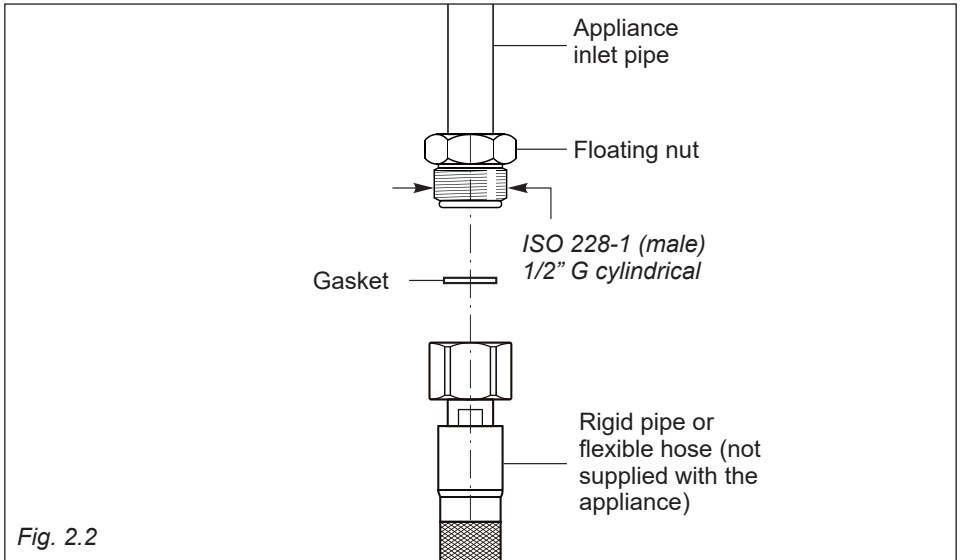

Fig. 2.2

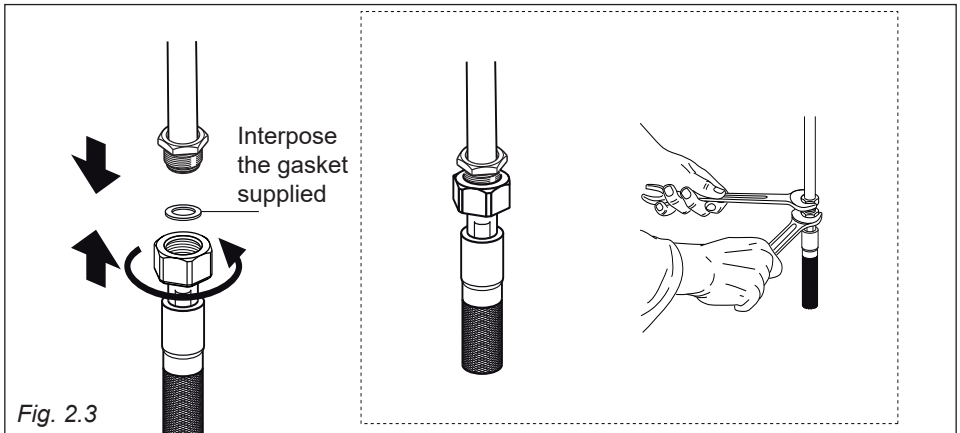

Fig. 2.3

ADDITIONAL GAS CONNECTION REQUIREMENTS

When connecting the appliance to the gas supply with rigid pipes or a flexible hose, make sure that:

- You use rigid pipes or a flexible hose compliant with applicable local regulations. The flexible hose shall be of the correct construction for the type of gas being used and of the correct size to maintain the heat output of the appliance.
- The connection with rigid metal pipes does not cause stress or pressure to the gas piping.
- The flexible hose is not under tension, twisted, kinked, or too tightly bent, neither while the appliance is in use nor while it is being connected or disconnected.
- The flexible hose is not longer than 2000 mm (or refer to applicable local regulations) and does not come into contact with sharp edges, corners, or moving parts, as these may cause abrasion. Use a single flexible hose only; never connect the appliance with more than one flexible hose.
- The flexible hose can easily be inspected along its entire length to check its condition; if it has an expiry date, it should be replaced before that date.
- If using a flexible hose which is not entirely made of metal, make sure that it does not come into contact with any part of the appliance with a surface temperature of 70°C or above (or refer to applicable local regulations).
- The rigid pipe or flexible hose is replaced if it shows signs of damage.
- The flexible hose is not subject to excessive heat by direct exposure to flue products or by contact with hot surfaces.
- The socket into which the plug of the flexible hose fit is permanently attached to a firmly fixed gas installation pipe and is positioned so that the hose hangs freely downwards.
- The plug of the flexible hose is accessible after installation, so that it can be disconnected for service or removal.
- You inform the customer that the rigid pipe or flexible hose should not be subjected to corrosion by cleaning agents.

GAS MAINTENANCE

TABLE FOR THE CHOICE OF THE INJECTORS

BURNERS	Nominal power		Reduced power		LPG (PROPANE/ BUTANE) 5 kPa	
	[g/h]	[kW]	[g/h]	[kW]	Ø injector [1/100 mm]	Ring opening [mm]
Oven	342	4,70	95	1,30	92	1 (*)
Grill	218	3,00	-	-	75	2 (*)

(*) Reference value

AIR VENT NECESSARY FOR GAS COMBUSTION = (2 m³/h x kW)

BURNERS	Air necessary for combustion [m ³ /h]
Oven	9,40
Grill	6,00

IMPORTANT

All intervention regarding installation and maintenance of the appliance must be fulfilled with original factory parts.

The manufacturer declines any liability resulting from the non-compliance of this obligation.

OPERATIONS TO BE EXECUTED FOR THE REPLACEMENT OF THE INJECTORS OF THE OVEN AND GRILL BURNERS

Some models are provided with a set of injectors for the various types of gas.

If the injectors are not supplied they can be obtained from the “Service Centre”.

Select the injectors to be replaced according to the “Table for the choice of the injectors”.

The nozzle diameters, expressed in hundredths of a millimetre, are marked on the body of each injector.

OVEN BURNER

- Lift and remove the lower panel inside the oven.
- Gently unlock, from the burner, the safety valve probe “V” and the ignition electrode “E” (as indicated in fig. 2.4a). Take care not to damage the probe and the ignition electrode.
- Unscrew and remove the burner securing screw “A” (fig. 2.4a).
- Withdraw the burner as shown in figure 2.4b.
- Using a 7 mm box spanner, unscrew the injector (indicated by the arrow in fig. 2.4b) and replace it with a new one selected in accordance with the “Table for the choice of the injectors”.
- Regulate the air supply to the oven burner as indicated in the section “REGULATION OF AIR SUPPLY TO OVEN AND GRILL BURNERS”; then replace the burner and the other components repeating the above steps in reverse order.

IMPORTANT: Pay special attention to replace correctly the safety valve probe “V” and the ignition electrode “E” as per figure 2.4a. Check the correct operation of the safety valve and the ignition electrode.

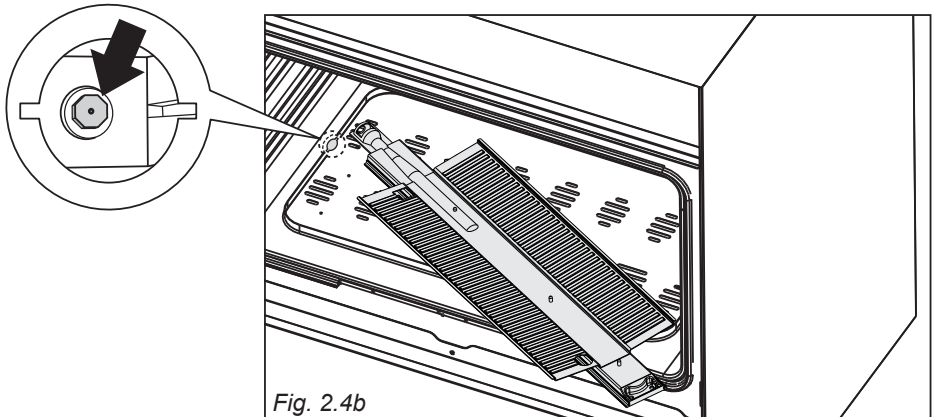
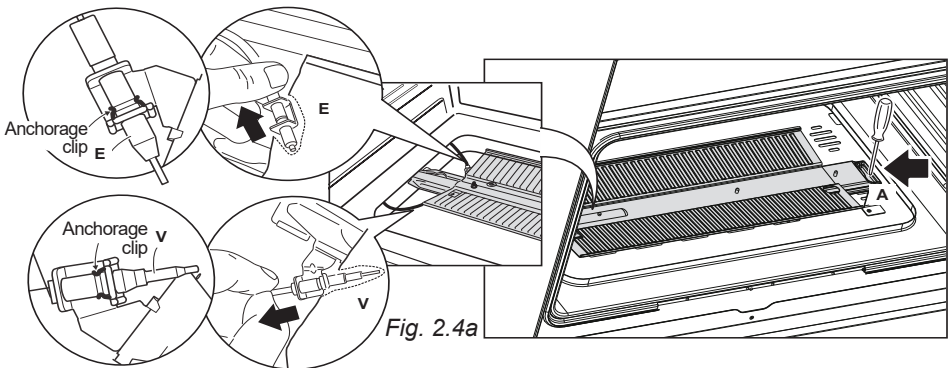

GRILL BURNER

- Gently unlock, from the burner, the safety valve probe “V” and the ignition electrode “E” (as indicated in fig. 2.5a). Take care not to damage the probe and the ignition electrode.
- Unscrew and remove the burner securing screw “A” (fig. 2.5a).
- Withdraw the burner as shown in figure 2.5b.
- Using a 7 mm box spanner, unscrew the injector (indicated by the arrow in fig. 2.5b) and replace it with a new one selected in accordance with the “Table for the choice of the injectors”.
- Regulate the air supply to the grill burner as indicated in the section “REGULATION OF AIR SUPPLY TO OVEN AND GRILL BURNERS”; then replace the burner and the other components repeating the above steps in reverse order.

IMPORTANT: Pay special attention to replace correctly the safety valve probe “V” and the ignition electrode “E” as per figure 2.5a. Check the correct operation of the safety valve and the ignition electrode.

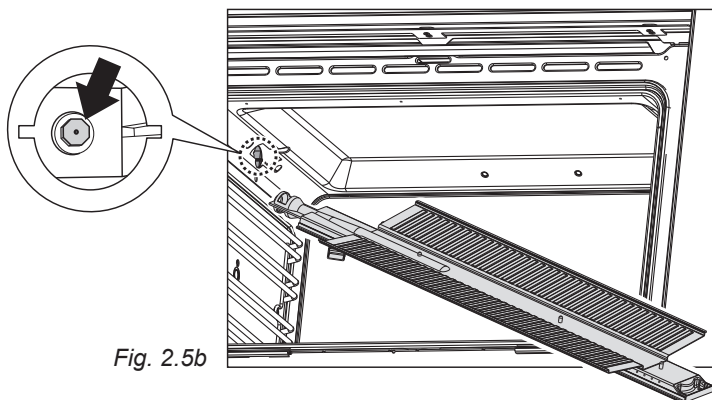
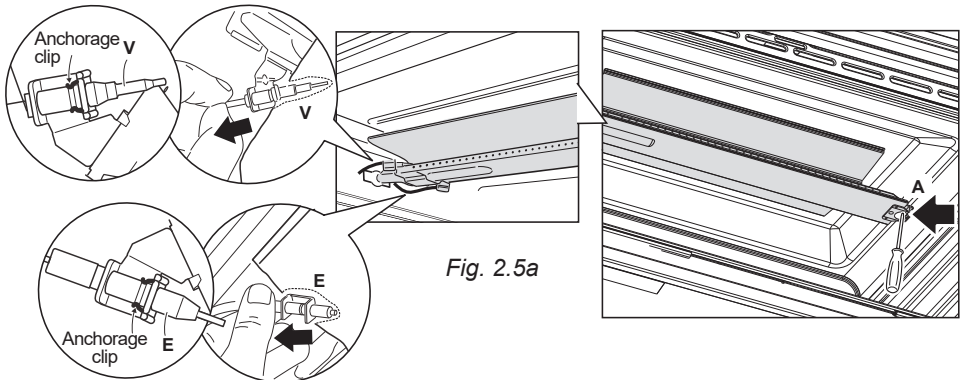

REGULATION OF AIR SUPPLY TO OVEN AND GRILL BURNERS

To regulate the air supply it is necessary to remove the burners from their housings (figs. 2.4b - 2.5b).

- Using a cross-head screwdriver, slacken the screws “A” securing the air flow regulation collar “B” (fig. 2.6) and move the collar forward or backward to increase or reduce the air aperture in accordance with gas type and the indications in the “Table for the choice of the injectors”.

IMPORTANT: If the air flow regulation collar “B” is not already fitted on the burner (e.g. oven burner set in the factory for LPG use), it is supplied with the kit for the gas conversion. In this case the air flow regulation collar “B” shall be fitted as indicated in figure 2.6:

- the collar “B” shall be folded around the burner (one half part at the top and one half part at the bottom);
 - the throttled section shall be oriented toward the burner deflector (opposite side with respect to the injector).
- Replace and light the burners to check the flames.

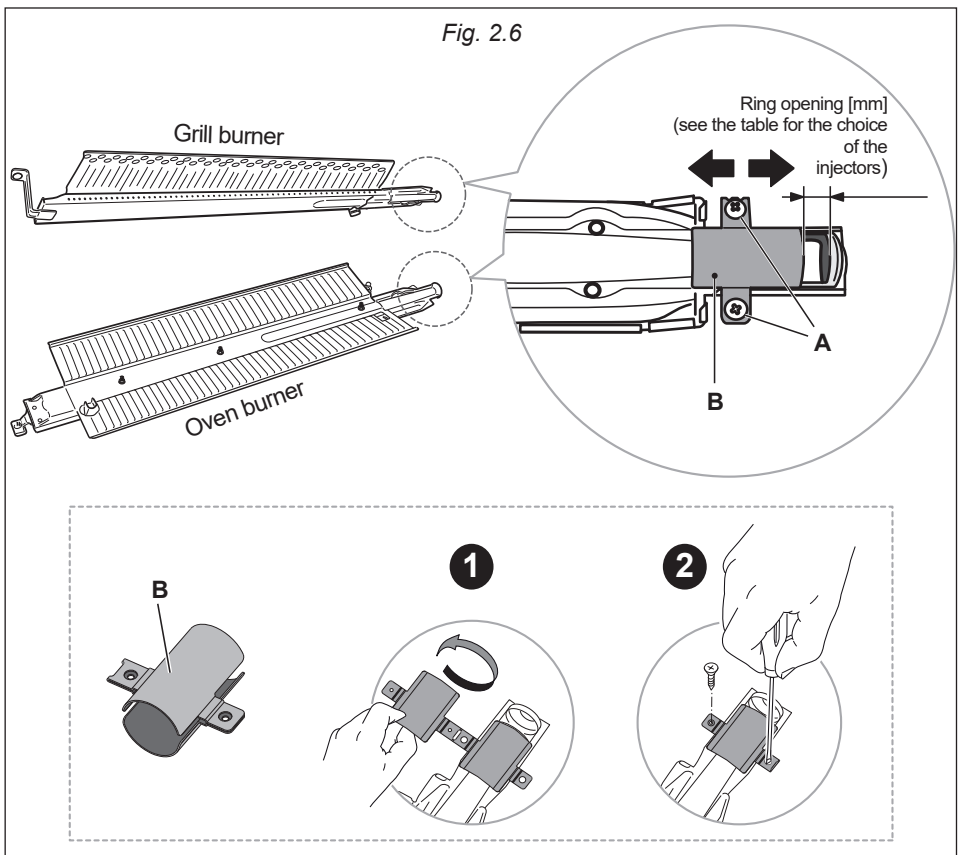

ADJUSTMENT OF THE OVEN BURNER MINIMUM

In the minimum position the flame must have a length of about 4 mm and must remain lit even with a brusque passage from the maximum position to that of minimum.

The flame adjustment is done in the following way:

- Remove the control panel (fig. 2.8). To do that, firstly remove the control knobs and then unscrew the no.11 fixing screws (no.2+2 "A" on the sides & no.3 "B" at the bottom of the control panel, and no.4 "C" at the top of the oven casing). Release the control panel from the oven (it is mechanically anchored at the top) as indicated by the arrows in fig. 2.8.
Pay special care to avoid any damages to the control panel and to prevent injuries to yourself.
- Remount the knob and turn on the oven burner by setting the thermostat knob on maximum position ("10" or "240" or **Max**★).
- Remove the knob and unscrew the by-pass screw "G" (fig. 2.7) about three times by using a small flat screwdriver.
- Remount the knob and let the oven heat up for about 15 minutes, then bring the knob to the minimum position ("1" or "130") to operate the thermostat by-pass.
- After having removed the knob again and being very careful not to turn the thermostat rod, slowly screw the by-pass screws "G" (fig. 2.7) until you obtain a flame of 3-4 mm in height.
- After having completed the regulation, refit the control panel and knobs correctly in place operating in reverse order (fig. 2.8).

N.B. For LPG the by-pass screw must be fixed thoroughly.

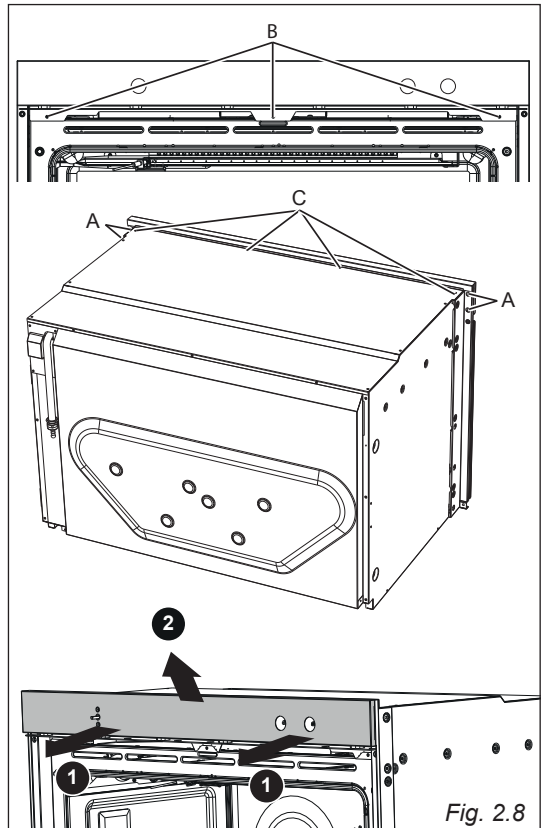
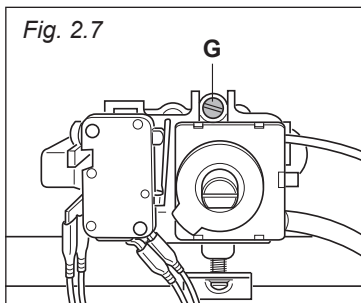

Flame faulty in primary air	Flame correct	Flame with excess primary air
flong, yellow and trembling	clear interior blue cone	short and sharp too blue interior cone tending to detach
CAUSE		
air regulating tube, too closed	correct distance of the tube	air regulating tube, too open



Flame correct



Flame faulty in primary air



Flame with excess primary air

3 ELECTRICAL SECTION

IMPORTANT: The appliance must be installed by a qualified technician according with the current local regulations and in compliance with the manufacturer instructions. Incorrect installation might cause harm and damage to people, animals or objects, for which the manufacturer accepts no responsibility.

GENERAL

- The connection to the electrical network must be carried out by qualified personnel and must be according to existing norms.
- The appliance must be connected to the electrical network verifying above all that the voltage corresponds to the value indicated on the specifications plate and that the cables section of the electrical plant can bear the load which is also indicated on the plate.
- If the appliance is supplied without a power supply plug and if you are not connecting directly to the mains, a standardized plug suitable for the load must be fitted.
- The colours of the wires in the appliance power cable may not correspond with the colours marked on the terminals of your electrical plug/fuse spur outlet. For the connection proceed as follows:
 - The wire which is coloured green and yellow must be connected to the terminal which is marked with letter **E** or by the \perp (Earth) symbol or coloured green and yellow.
 - The wire which is coloured blue must be connected to the terminal which is marked with the letter **N** (Neutral) or coloured black.
 - The wire which is coloured brown must be connected to the terminal which is marked with letter **L** (Live) or coloured red.
- The bi-polar plug must be connected to an outlet connected to the grounding unit in conformity to security norms.
- If the oven is to be connected directly to the mains, it must be placed with an omnipolar switch with minimum opening between the contacts of 3 mm between the appliance and the mains.
- The power supply cable must not touch the hot parts and must be positioned so that it does not exceed 50°C at any point.
- Once the oven has been installed, the switch or socket must always be accessible.
- If the power supply cable is damaged it must be substituted by a suitable cable available in the after sales service.

N.B. For connection to the mains, do not use adapters, reducers or branching devices as they can cause overheating and burning.

If the installation requires alterations to the domestic electrical system call an expert. He should also check that the domestic electrical system is suitable for the power absorbed by the appliance.

Before effecting any intervention on the electrical parts the appliance must be disconnected from the network.

The connection of the appliance to the grounding unit is mandatory. The manufacturer declines every responsibility for any inconvenience resulting from the inobservance of this condition.

CONNECTION OF THE POWER SUPPLY CABLE

WARNING: If the power supply cable is damaged, it must be replaced only by an authorised service agent in order to avoid a hazard.

- Unhook the terminal board cover by inserting a screwdriver into the two hooks “A” (fig. 3.1).
- Open the cable gland by unscrewing screw “F” (fig. 3.2), unscrew the terminal screws and remove the cable.
- The new supply cable, of suitable type and section, is connected to the terminal board following the diagram of fig. 3.3.

N.B. The earth conductor must be left about 3 cm longer than the others.

IMPORTANT: To connect the power supply cable **DO NOT** unscrew the screws fixing the cover plate behind the terminal block.

The operations must be executed by a qualified technician.

FEEDER CABLE SECTION TYPE “H05RR-F” or “H05V2V2-F” (resistance to temperatures of 90°C).

220-240 V ac 3 x 0,75 mm² (*) (**)

(*) Connection possible with plug and outlet

(**) Connection with wall box connection.

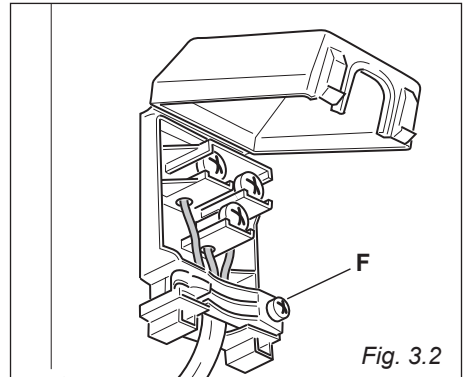

Fig. 3.2

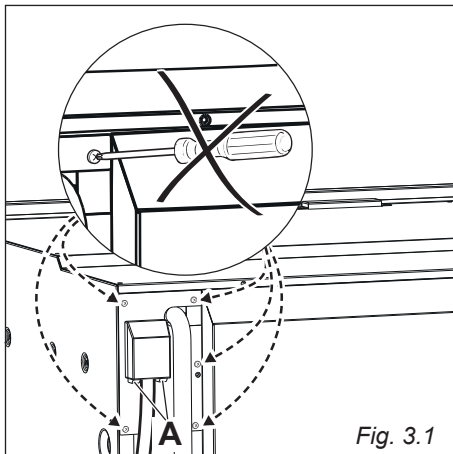

Fig. 3.1

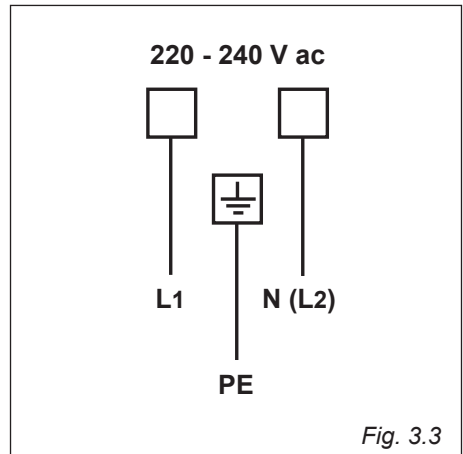

Fig. 3.3

ADVICE
for the
USERS

1

CONTROL PANELS

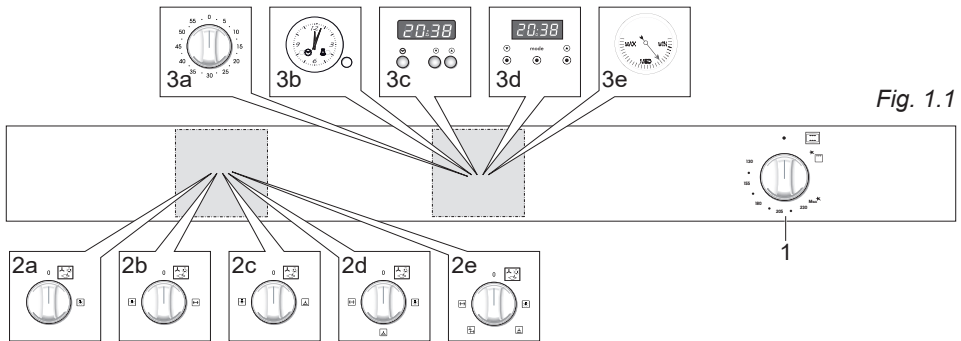

Fig. 1.1

CONTROLS DESCRIPTION

1. Gas oven/grill thermostat control knob
2. Depending on the models:
 - a. Oven light control knob
 - b. Oven light / rotisserie control knob
 - c. Oven light / fan motor control knob
 - d. Oven light / fan motor / rotisserie control knob
 - e. Oven light / fan motor / fan motor and rotisserie / rotisserie control knob
3. Depending on the models:
 - a. 60' or 120' alarm control knob
 - b. Electric clock with alarm
 - c. Electronic clock with alarm
 - d. Digital electronic clock with timer (with "Touch-control" keys)
 - e. Oven thermometer

NOTES:

The knobs and symbols may vary.
The symbols may be printed on the knob itself.

Notes:

- The electric ignition is incorporated in the thermostat control knob.
- The appliance has a safety valve system fitted, the flow of gas will be stopped if and when the flame should accidentally go out.

CAUTION:

If the burner is accidentally extinguished, turn the gas off at the control knob and wait at least 1 minute before attempting to relight.

CAUTION:

Gas appliances produce heat and humidity in the environment in which they are installed. Ensure that the cooking area is well ventilated by opening the natural ventilation grilles or by installing an extractor hood connected to an outlet duct.

CAUTION:

If the appliance is used for a prolonged time it may be necessary to provide further ventilation by opening a window or by increasing the suction power of the extractor hood (if fitted).

2 HOW TO USE THE OVEN

ATTENTION:

The oven door becomes very hot during operation and very hot steam goes out from the area below the control panel. Keep children away.

The door is hot, use the handle.



During use the appliance becomes hot. Care should be taken to avoid touching the heating elements inside the oven.

Do not line the oven walls or floor with aluminium foil. Do not place baking trays or the drip tray on the base of the oven chamber.

TECHNICAL FEATURES

The oven is furnished completely clean. It is advisable however, upon first use, to turn the oven on to the maximum temperature to eliminate possible traces of grease from the oven burner. The same operation shall be done with the gas grill.

This oven is fitted with:

- One gas oven burner (4,70 kW - 342 g/h), located at the bottom, providing self-ignition and safety device.
- One gas grill burner (3,00 kW - 218 g/h), placed on the top, providing self-ignition and safety device.
- **Only for the “fan assisted” models (models having also the position  or )** - A fan motor, positioned on the back panel of the oven cavity, which can be used in combination with the oven gas burner or alone, without heating.

IMPORTANT NOTE - It is not possible to use the fan motor in combination with the gas grill: a safety device switches off the fan motor when the gas grill control knob is turned on grill position.

OPERATING PRINCIPLES

Heating and cooking in the gas oven are obtained in the following ways:

a. by normal convection

The heat is produced by the oven gas burner.

b. by forced convection (only for the “fan assisted” models - models having also the position or)

The heat produced by the oven burner is distributed throughout the oven by the fan. (In the position  also the rotisserie motor is operating).

c. by radiation

The heat is radiated by the gas grill.

d. by ventilation (only for the “fan assisted” models - models having also the position)

The food is defrosted by using the fan only without oven burner (this is not a cooking function).

COOLING FAN MOTOR

This appliance incorporates a safety cooling fan motor to achieve optimum efficiency of the controls, ensure lower surface temperatures are maintained and cool the internal components.

The cooling fan motor turns on automatically when igniting the oven or grill burner.

It may run on (for various minutes) even after the oven or grill burner has been turned off.

IMPORTANT NOTES:

- Do not use the appliance in case of power failure or if the cooling fan motor is damaged. The appliance may overheat and get damaged due to the non-operation of the cooling fan motor.
- In case of failure of the cooling fan motor during the operation of the gas oven or gas grill, the oven or grill burner is turned off automatically after about 20 minutes. In that case do not use the oven or the grill and contact the after-sales service.
- When the cooling fan motor is operating correctly there is an air flow in the top area of the appliance.

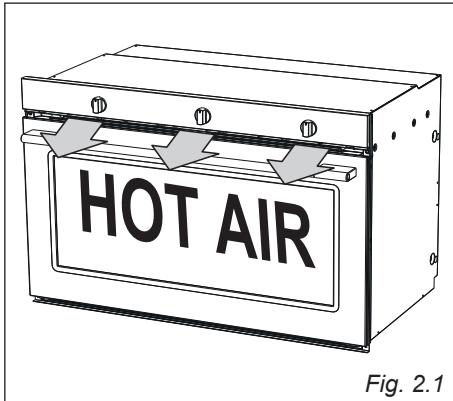

Fig. 2.1



OVEN BURNER

The gas flow to the burner is regulated by a thermostat which allow to maintain the oven temperature constant.

The control of the temperature is assured by a thermostatic probe positioned inside the oven. The probe must be always kept in its housing, in a clean condition, as an incorrect position or encrustment may cause an alteration in the control of the temperature.

Moreover, the thermostat is fitted with a safety valve which automatically shuts off the gas supply when the flame goes out.

THERMOSTAT

The numbers printed on the control panel or on the knob (fig. 2.2) indicate the increasing oven temperature value (see table below). To regulate the temperature, set the knob to the chosen number. The "FAN ASSISTED GAS OVEN" column refers to the oven burner used in combination with the fan motor (forced convection cooking: only for the "fan assisted" models - models having also the position  or ), while the "GAS OVEN" column refers to the oven burner used in the normal convection mode (without fan motor). The ★ symbol close to the maximum position indicates that the electric ignition is incorporated into the knob (activated by the knob itself).

NOTES: The knob and symbols may vary. The symbols may be printed on the knob itself.

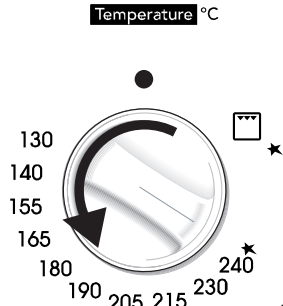

Fig. 2.2

THERMOSTAT GRADE TABLE (°C)

Knob position	GAS OVEN	FAN ASSISTED GAS OVEN
130 (or 1)	130	130
140 (or 2)	140	140
155 (or 3)	155	155
165 (or 4)	165	165
180 (or 5)	180	180
190 (or 6)	190	190
205 (or 7)	205	205
215 (or 8)	215	215
230 (or 9)	230	230
240 (or 10 or Max)	240	240

LIGHTING OF OVEN BURNER

IMPORTANT: The oven door must be open during this operation.

To light the oven burner:

- 1 – Open the oven door to the full extent.



If this operation is not performed you should not proceed to light the oven.

- 2 – Lightly press and turn the thermostat knob anti-clockwise to the maximum position  (fig. 2.2). Press the knob firmly until the burner lights.

Never continue this operation for more than 15 seconds. If the burner has still not ignited, wait for about 1 minute prior to repeating the ignition.

In case of problems with the electric ignition, approach a lighted match or taper to the opening “A” (fig. 2.3) and immediately press the knob firmly.

- 3 – Wait about 10/15 seconds after the burner lighting before releasing the knob (time of priming of the valve).
- 4 – Check that the burner has lit; if not, turn the knob clockwise back to “0”, “●” or “○” (OFF) and repeat the procedure from step 1.
- 5 – Close the oven door slowly and adjust the burner according to the power required.

If the flame extinguishes for any reason, the safety valve will automatically shut off the gas supply to the burner.

To re-light the burner, first turn the oven control knob to OFF position (“0”, “●” or “○”), **wait for at least 1 minute** and then repeat the lighting procedure.

For the correct use of the gas oven see the chapters “COOKING WITH GAS OVEN” and “COOKING WITH FAN ASSISTED GAS OVEN” (only for the “fan assisted” models -

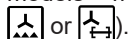

During and after use of the oven, certain parts will become very hot. Keep children away.

ATTENTION: In case of manual lighting, never turn the thermostat before approaching a flame to the hole “A” of the floor.

For correct use of the gas oven, always preheat it (bottom burner) for at least 15 minutes.

Preheating should always be carried out with the oven empty: remove the trays and racks from the oven cavity.

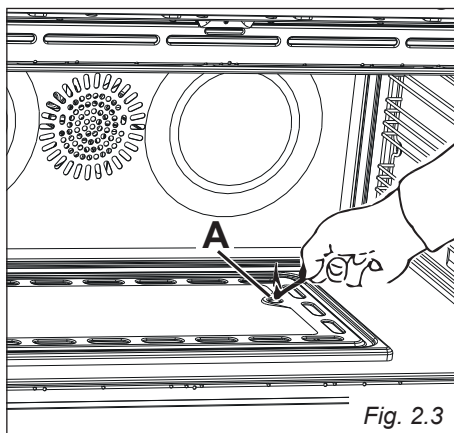



Fig. 2.3

IGNITION OF THE GRILL BURNER

IMPORTANT: The oven door must be open during this operation.

To ignite the grill burner:

- 1 – Open the oven door to the full extent.

 **WARNING:** Risk of explosion! The oven door must be open during this operation.

- 2 – Lightly press and turn the thermostat knob clockwise to the position  (fig. 2.4), Press the knob firmly until the burner lights.

Never continue this operation for more than 15 seconds. If the burner has still not ignited, wait for about 1 minute prior to repeating the ignition.

In case of mains failure, approach a lighted match or taper to the pipe of the burner (fig. 2.5a) and immediately press the knob firmly.

Never turn the thermostat before approaching a flame to the burner.

- 3 – Wait about 10/15 seconds after the burner lighting before releasing the knob (time of priming of the valve).

If the flame extinguishes for any reason, the safety valve will automatically shut off the gas supply to the burner.

To re-light the burner, first turn the thermostat control knob to position “●” or “O” (off), wait for at least 1 minute and then repeat the lighting procedure.

For the correct use of the gas grill see specific instructions in the section ‘USE OF THE GRILL’.

ATTENTION: the oven door becomes very hot during operation. Keep children away.

During and after use of the grill, certain parts will become very hot. Keep children away.

ATTENTION: In case of manual lighting, never turn the thermostat before approaching a flame to the burner.

NOTES: The knob and symbols may vary. The symbols may be printed on the knob itself.

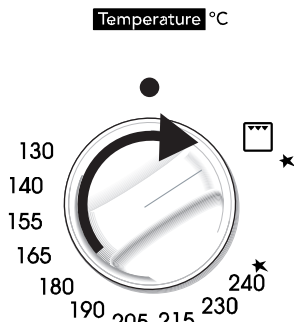

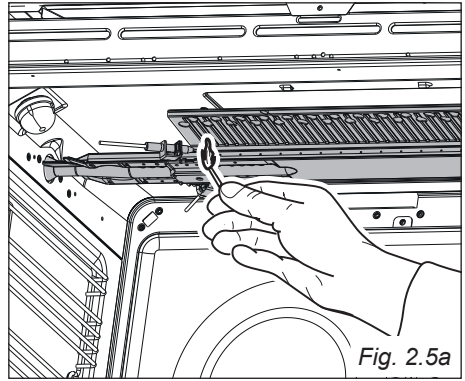

Fig. 2.4

IMPORTANT NOTE (Only for the “fan assisted” models - models having also the position  or ): It is not possible to use the fan motor in combination with the gas grill; a safety device switches off the fan motor when the gas oven/grill control knob is turned on grill position.



OVEN THERMOMETER (SOME MODELS ONLY)

The thermometer allows to have a general (non-exhaustive) indication of the oven heating level (MIN, MED, MAX) (fig. 2.5b).

To set the temperature, always refer to the oven temperature control knob.

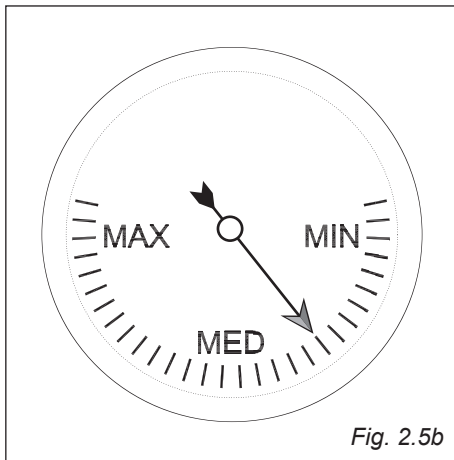

COOKING WITH GAS OVEN

Once the oven gas burner has been lit, close the oven door and preheat the oven for at least 15 minutes. Preheating should always be carried out with the oven empty: remove the trays and racks from the oven cavity.

Once the oven has been preheated, insert the food you intend to cook.



Check the cooking time and turn off the oven 5 minutes before the theoretical time to recuperate the stored heat.

FAN MOTOR (Only for the “fan assisted” models - models having also the position or)

The fan motor is designed to distribute throughout the oven the heat generated by the oven gas burner.

The fan motor can also be used without the oven gas burner (without heating) to defrost frozen foods.

The fan is controlled by a knob (fig. 2.6a, 2.6b or 2.6c).

- To operate the fan motor turn the knob indicated in fig. 2.6a, 2.6b or 2.6c to  or  position. (In the position  also the rotisserie motor is operating).
- To switch it off turn the knob to the off position (“O” or “0”).

IMPORTANT: When using the fan motor together with the oven gas burner, switch on the fan only after the ignition of the gas burner.

Only for the “fan assisted” models - models having also the position .

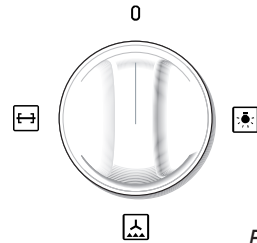



Fig. 2.6a

NOTES: The knob and symbols may vary. The symbols may be printed on the knob itself.

Only for the “fan assisted” models - models having also the position .

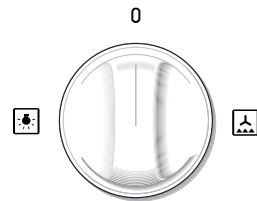



Fig. 2.6b

NOTES: The knob and symbols may vary. The symbols may be printed on the knob itself.

Only for the “fan assisted” models - models having also the position  or .

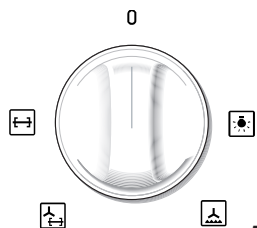



Fig. 2.6c

NOTES: The knob and symbols may vary. The symbols may be printed on the knob itself.

COOKING WITH FAN ASSISTED GAS OVEN (Only for the “fan assisted” models - models having also the position  or )

OVEN BURNER AND FAN MOTOR

Once the oven gas burner has been lit, close the oven door and preheat the oven for at least 15 minutes. Preheating should always be carried out with the oven empty: remove the trays and racks from the oven cavity.

Once the oven has been preheated, switch on the fan and insert the food you intend to cook.

Check the cooking time and turn off the oven 5 minutes before the theoretical time to recuperate the stored heat.

For correct use of the gas oven, always preheat it (bottom burner) for at least 15 minutes. Preheating should always be carried out with the oven empty: remove the trays and racks from the oven cavity.

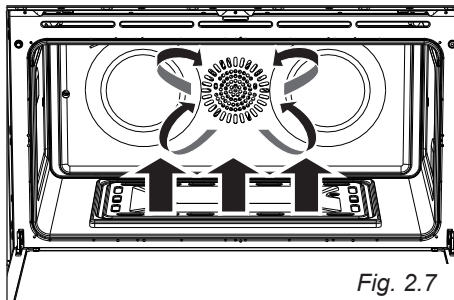

DEFROSTING FROZEN FOODS (Only for the “fan assisted” models - models having also the position ) **FAN MOTOR ONLY**

Switch on the fan motor only. The oven thermostat control knob shall be in the “0”, “●” or “○” (OFF) position. The defrosting is done by simple ventilation without heat.

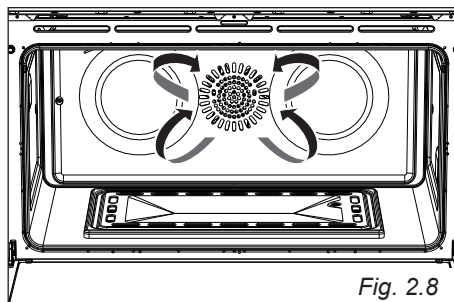

USE OF THE GRILL

Very important: The grill must always be used with the oven door closed.

Turn on the grill, as explained in the preceding paragraphs and let the oven preheat for about 5 minutes with the door closed.

Introduce the food to be cooked, positioning the rack as close to the grill as possible. The dripping pan should be placed under the rack to catch the cooking juices and fats.

Note: It is recommended that you do not grill for longer than 60 minutes at any one time.

Attention: The oven door becomes very hot during operation. Keep children away.

OVEN LIGHT

The oven provides an interior lamp to allow the visual inspection during the cooking.

To light the oven lamp turn the knob (fig. 2.6a, 2.6b, 2.6c or 2.9a or 2.9b) to the symbol .

NOTES: The knob and symbols may vary. The symbols may be printed on the knob itself.

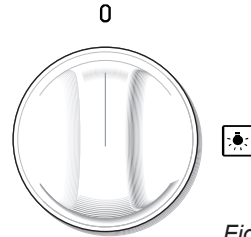

Fig. 2.9a

NOTES: The knob and symbols may vary. The symbols may be printed on the knob itself.

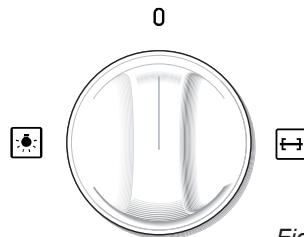



Fig. 2.9b

ROTISSERIE (MODELS WITH ROTISSERIE ONLY)

This is used for spit roasting under the grill and comprises:

- an electric motor fitted to the rear of the oven;
- a stainless steel skewer provided with slide-out heatless handgrip and two sets of adjustable forks;
- a skewer support to be fitted in the middle runner.

The rotisserie motor is operated by a switch knob (fig. 2.6a or 2.9b-  or  position).

The rotation direction of the rotisserie can be either clockwise or counter-clockwise.

USE OF THE ROTISSERIE (fig. 2.10)

- Insert the tray into the lowest rack holders of the oven and insert the rod support into the intermediate rack holders.
- Put the meat to be cooked onto the rod, being careful to secure it in the center with the special forks.

Important!

Take care, the forks are sharp!

- Insert the rod into the side gear opening "P" (fig. 2.10).
- Remove the grip "H" by turning it to the left.
- Insert completely the rotisserie support; the shaft "S" must be inserted in the spit motor collar "G".
- Fit the heat shield and switch on the grill and turnspit. The rotation direction of the rotisserie can be either clockwise or counterclockwise.

Attention: The oven door becomes very hot during operation.

Keep children away.

It is recommended that you do not grill for longer than 60 minutes at any one time.

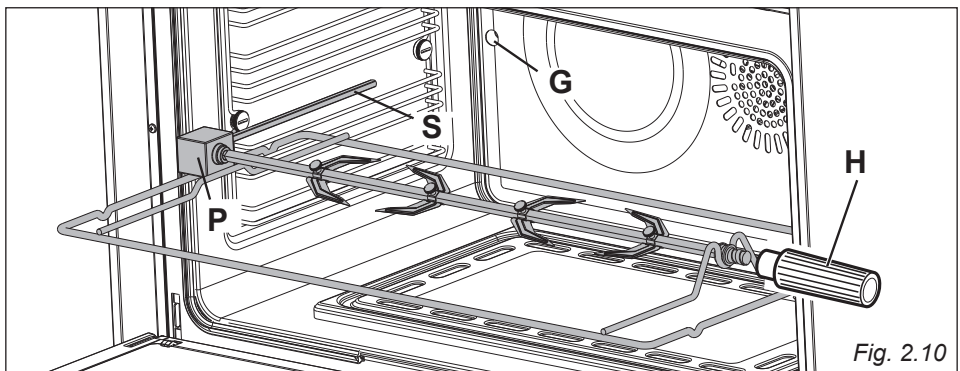

3

ALARM, ELECTRIC OR ELECTRONIC CLOCK

60' ALARM (fig. 3.1)

The timer is equipped with a time buzzer and may be regulated for a maximum period of 60 minutes.

The regulating knob must be turned in a clockwise direction until it reaches the 60 minutes position and then turned to the desired time by turning the knob in a counterclockwise direction.

120' ALARM (fig. 3.2)

The timer is equipped with a time buzzer and may be regulated for a maximum period of 120 minutes.

The regulating knob must be turned in a clockwise direction until it reaches the 120 minutes position and then turned to the desired time by turning the knob in a counterclockwise direction.

ATTENTION - MOST IMPORTANT:

This is only a mechanical timer that DOES NOT switch off the oven or grill. REMEMBER TO TURN OFF THE OVEN OR GRILL MANUALLY.

**NOTES: The knob and symbols may vary.
The symbols may be printed on the knob itself.**

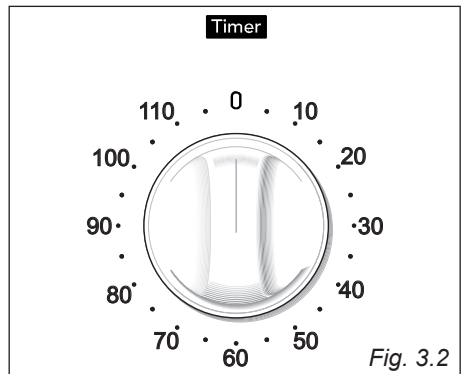
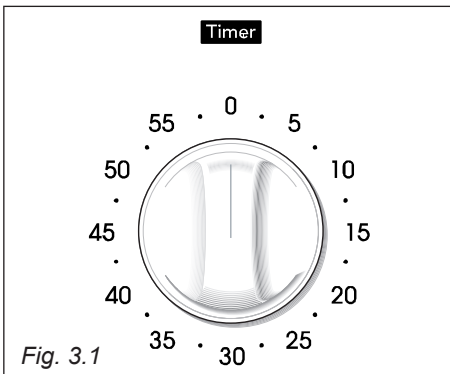

MODELS WITH ELECTRIC CLOCK WITH MINUTE MINDER (fig. 3.3)

The electric clock is a device which groups the following functions:

- 12-hour analog clock;
- minute minder (max 3 hours);
- acoustic signal (beep) which is activated each time the “setting knob” is pressed or at the end of the minute minder function.

ELECTRIC CLOCK

Upon immediate connection of the oven or after a blackout, the “clock indicator light” is flashing. This indicates that it is recommended to check if the time of the day is correct.

- If the time of the day is correct keep the “setting knob” pressed until the “clock indicator light” goes out.
- To set the time of the day press the “setting knob” briefly (repeatedly) until the “clock indicator light” is flashing. Then turn the “setting knob” (to the right or left) to set the time of the day. At the end of the time adjustment, keep the “setting knob” pressed for confirmation until the “clock indicator light” goes out.

MINUTE MINDER

The minute minder function consists only of a buzzer which is automatically activated at the end of the set time (max 3 hours).

To set the minute minder press the “setting knob” briefly (one or more times) until the “minute minder indicator light” is flashing.

Then turn the “setting knob” (to the right or left) to set the time.

At the end of the adjustment (within 10 seconds), keep the “setting knob” pressed for confirmation until the “minute minder indicator light” changes from flashing to steadily lit.

Then the countdown starts immediately.

At the end of the time, the “minute minder indicator light” changes from steadily lit to flashing and a buzzer (beep) sounds for one minute.

Press the “setting knob” briefly to stop the buzzer and to turn off the flashing “minute minder indicator light”.

During the minute minder program it is possible, at any time, to display the set time by pressing the “setting knob” briefly (one or more times) until the “minute minder indicator light” is flashing.

To cancel the program before completion, keep the “setting knob” pressed for about 3 seconds; the minute minder function will be cancelled.

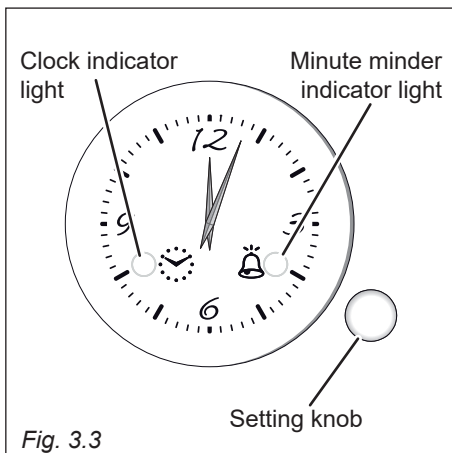

Fig. 3.3

ATTENTION - MOST IMPORTANT:
This is only an alarm that DOES NOT switch off the oven or grill.
REMEMBER TO TURN OFF THE OVEN OR GRILL MANUALLY.





ELECTRONIC CLOCK WITH ALARM

(fig. 3.4)

The electronic clock is a device which groups the following functions:

- 24 hours clock with illuminated display;
- 99 minutes alarm.





Upon immediate connection of the oven or after a blackout, three zeros will flash on the display.



To set the hour it is necessary to push the  button and then, within 7 seconds, the  () or  () button until you have set the exact hour.







An energy black-out makes the clock go to zero.

ELECTRONIC ALARM

The alarm program consists only of a buzzer which may be set for a maximum period of 99 minutes.

To set the time, push the  () or  () button until you obtain the desired time in the display. Having finished the setting, the  symbol will be lighted and the countdown will start immediately.



At the end of the time, an intermittent buzzer, during 7 minutes, will go off; this can be stopped by pressing the  () button.

To stop the alarm countdown in any moment press the  () and  () buttons together and release the  () button first.

ATTENTION - MOST IMPORTANT:

This is only an electronic alarm that DOES NOT switch off the oven or grill. REMEMBER TO TURN OFF THE OVEN OR GRILL MANUALLY.



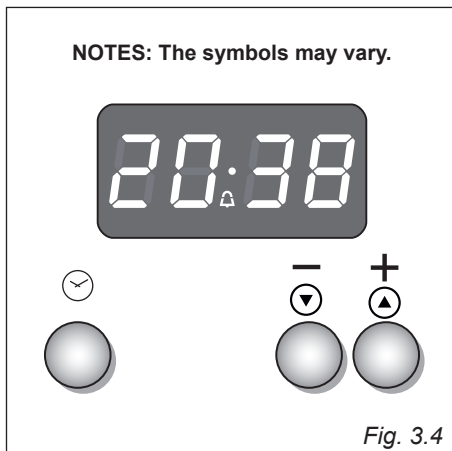

SETTING THE FREQUENCY OF THE ALARM SOUND

The selection from 3 possibilities of sound can be made by pressing the  () button.





DIGITAL ELECTRONIC CLOCK WITH TIMER (fig. 3.5)

CLOCK and TIMER with “TOUCH CONTROL” KEYS

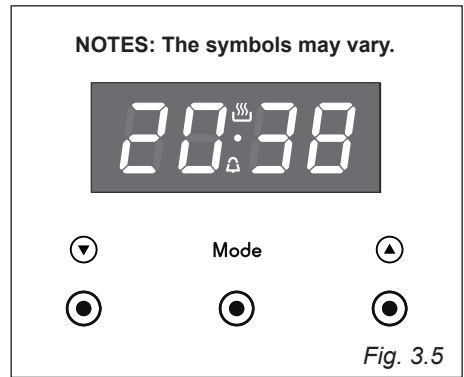
Keys:	
 and 	<p>T o u c h e d simultaneously (for more than 2 seconds):</p> <ul style="list-style-type: none"> • setting the clock; • setting the timer volume (by touching once, along with the “MODE” key).
“MODE”	<p>Function selection (touched for more than 2 seconds):</p> <ul style="list-style-type: none"> • setting the clock (only after first connection or after a power failure); • timer.
	Increases the number shown on the display
	Decreases the number shown on the display





Illuminated symbols:		
	flashing	Timer being set
	steady illumination	Timer in operation

ATTENTION - MOST IMPORTANT:
This is only an alarm that DOES NOT switch off the oven or grill.
REMEMBER TO TURN OFF THE OVEN OR GRILL MANUALLY.

“TOUCH-CONTROL” KEYS



The “touch-control” keys shall be operated by the fingers (just by touching the key). When using touch controls it is best to use the ball of your finger rather than the tip. The keys are automatically deactivated:





- 8 seconds after the last selection; the deactivation is indicated by an acoustic signal (“beep”).

To reactivate just touch the “MODE” key or the “” and “” keys (simultaneously) for more than 2 seconds.

SETTING THE CLOCK

When first connected, or after a power failure, the digits will flash on the display.

To set the clock, touch the “ **MODE** ” key, for more than 2 seconds, and then the “  ” or “  ” keys.







To set the clock, with the appliance already connected, touch the “  ” and “  ” keys simultaneously (for more than 2 seconds), then “  ” or “  ” keys.

USING THE TIMER

You can use the timer at any time, even when the oven is not in use.



The timer does not turn the oven off.

The timer can be set for up to 23 hours and 59 minutes.

- To set the timer, touch the “ **MODE** ” key for more than 2 seconds (the “  ” symbol flashes), then the “  ” or “  ” keys.
- After about 8 seconds an acoustic signal (“**beep**”) will sound confirming the regulation (“  ” symbol steady illuminated).
- To check the remaining time touch the “ **MODE** ” key for more than 2 seconds. If the remaining time is more than a minute the display will show hours and minutes; if less than a minute the display will show seconds.
- When the time is up, the timer will beep. Touch the “ **MODE** ” key , for more then 2 seconds, to turn it off; or press the “  ” or “  ” key to stop the beep and than the “ **MODE** ” key, for more than 2 seconds, to deactivate the “  ” symbol flashing on the display.
- Turn off the oven manually (thermostat knob in the off position) if the cooking has been completed.

SETTING THE TIMER VOLUME

You can select from three volume levels.

- Touch the “  ” and “  ” keys simultaneously for more than 2 seconds.
- Touch the “ **MODE** ” key; you can read on the display the current timer volume (“**ton1**”, “**ton2**” or “**ton3**”).
- Touch the “  ” key to listen or change the timer volume.
- Timer volume activated: the last displayed.
- After about 8 seconds an acoustic signal (“**beep**”) will sound confirming the volume setting; then the time of day will be displayed.

4

CLEANING AND MAINTENANCE

GENERAL ADVICE

Important:

Before any operation of cleaning and maintenance disconnect the appliance from the electrical supply.

- It is advisable to clean when the appliance is cold and especially for cleaning the enamelled parts.
- Avoid leaving alkaline or acidic substances (lemon juice, vinegar, etc.) on the surfaces.
- Avoid using cleaning products with a chlorine or acidic base.
- The oven must always be cleaned after every use, using suitable products.
- **Important: The use of suitable protective clothing/gloves is recommended when handling or cleaning of this appliance.**

WARNING

When correctly installed, your product meets all safety requirements laid down for this type of product category.

However special care should be taken around the rear or the underneath of the appliance as these areas are not designed or intended to be touched and may contain sharp or rough edges, that may cause injury.

INSIDE OF OVEN

The oven should always be cleaned after use when it has cooled down.

The cavity should be cleaned using a mild detergent solution and warm water.

Suitable proprietary chemical cleaners may be used after first consulting with the manufacturers recommendations and testing a small sample of the oven cavity.

Abrasive cleaning agents or scouring pads/cloths should not be used on the cavity surface.

NOTE: The manufacturers of this appliance will accept no responsibility for damage caused by chemical or abrasive cleaning.

Let the oven cool down and pay special attention no to touch the hot heating elements inside the oven cavity.

Important: The manufacturer declines all liability for possible damage caused by the use of unsuitable products to clean the appliance.

Do not use a steam cleaner because the moisture can get into the appliance thus make it unsafe.



Do not store flammable material in the oven.

Do not use harsh abrasive cleaners or sharp metal scrapers to clean the oven door glass since they can scratch the surface, which may result in shattering of the glass.

ENAMELLED PARTS

All the enamelled parts must be cleaned with a sponge and soapy water or other non-abrasive products.

Dry preferably with a microfibre or soft cloth.

Acidic substances like lemon juice, tomato sauce, vinegar etc. can damage the enamel if left too long.

STAINLESS STEEL SURFACES (MODELS WITHOUT ANTI-FINGERPRINT TREATMENT), ALUMINIUM PARTS AND PAINTED OR SILK-SCREEN PRINTED SURFACES

Clean using an appropriate product. Always dry thoroughly.

IMPORTANT: these parts must be cleaned very carefully to avoid scratching and abrasion. You are advised to use a soft cloth and neutral soap.

STAINLESS STEEL SURFACES WITH ANTI-FINGERPRINT TREATMENT (SOME MODELS ONLY)

CAUTION: The stainless steel front surfaces used in some ovens are protected with a Special Lacquer to reduce finger-print marks.

To avoid damaging this lacquer, do not clean the stainless steel with abrasive cleaners or abrasive cloths or scouring pads.

ONLY SOAP/WARM WATER MUST BE USED TO CLEAN THE STAINLESS STEEL SURFACES.

GLASS CONTROL PANEL (MODELS WITH GLASS CONTROL PANEL)

Clean using an appropriate product.

Always dry thoroughly.

Do not use harsh abrasive cleaners or sharp metal scrapers to clean the control panel since they can scratch the surface, which may result in shattering of the glass.

OVEN FITTING OUT

- Assemble the wire racks to the oven walls using the 2 screws (fig. 4.1).
- Slide in, on the guides, the shelf and the tray (fig. 4.2).
The shelf must be fitted so that the safety catch, which stops it sliding out, faces the inside of the oven.
Some models only: The shelf must be fitted so that the safety catch, which stops it sliding out, faces the inside of the oven; the guard rail shall be at the back.
- To dismantle, operate in reverse order.

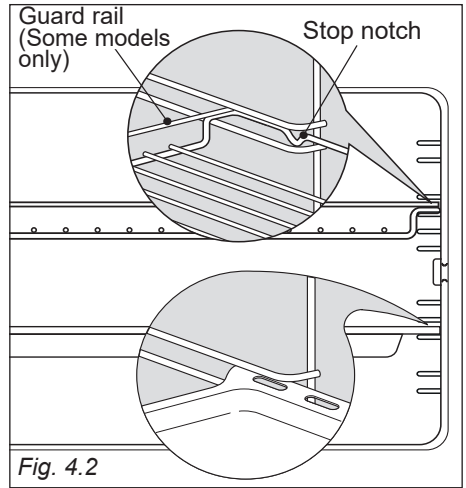
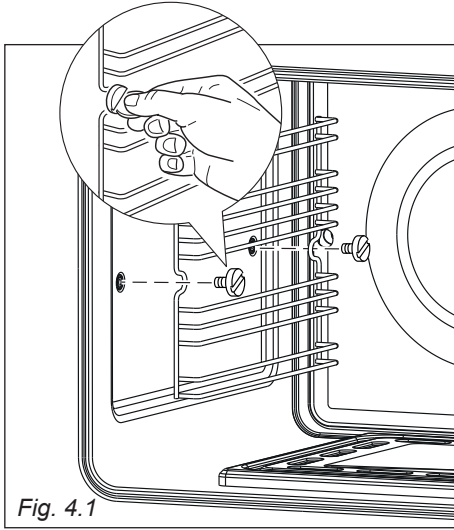

GREASE FILTER - FAN ASSISTED OVENS (SOME MODELS ONLY)

- A special screen is provided at the back of the oven to catch grease particles, mainly when meat is being roasted (fig. 4.3).
- When baking pastry etc. this filter should be removed.
- Slide in the grease filter on the back of the oven as in fig. 4.3.
- **Clean the filter after any cooking!**
The grease filter can be removed for cleaning and should be washed regularly in hot soapy water. Always clean the filter after cooking as any solid residues on it might adversely affect the oven performance.
- Always dry the filter properly before fitting it back into the oven.

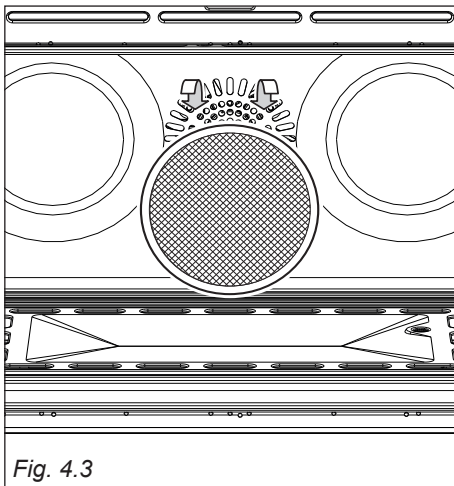

REPLACING THE OVEN LIGHTS

(NOTE: DEPENDING ON YOUR MODEL, YOUR OVEN MAY ONLY HAVE SOME OF THESE LIGHTS)

WARNING: Ensure the appliance is switched off before replacing the lamp to avoid the possibility of electric shock.

- Let the oven cavity and the heating elements to cool down.
- Switch off the electrical supply.
- Remove the protective cover (figs. 4.4a - 4.4b).
- Replace the halogen lamp with a new one suitable for high temperatures having the following specifications: 220-240 V ac and same power (check watt power as stamped in the bulb itself) of the replaced lamp.

IMPORTANT WARNING: Never replace the lamp with bare hands; contamination from your fingers can cause premature failure. Always use a clean cloth or gloves.

- Refit the protective cover.

NOTE: Oven bulb replacement is not covered by your guarantee.

The intended purpose of the lamps, fitted on this appliance, is to illuminate the oven cavity and thus help the user to better monitor the food while cooking. These lamps are not suitable for other usage (e.g. environments lighting).

This product contains more than one light source of energy efficiency class G.

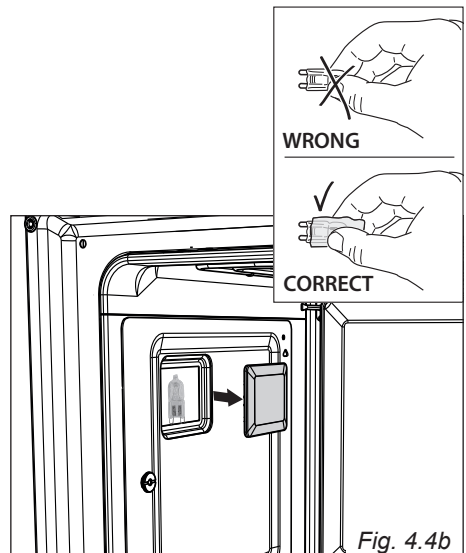
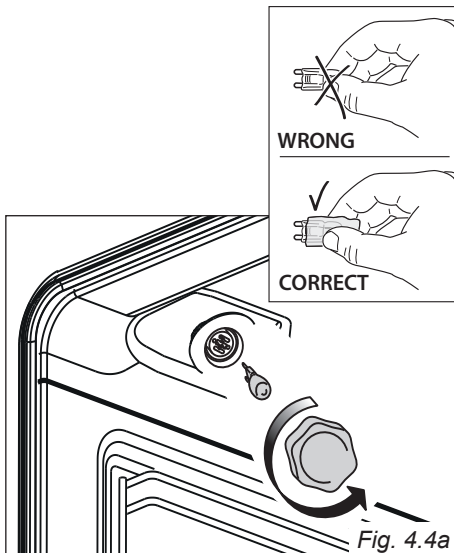

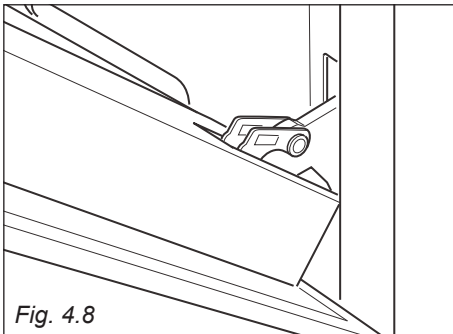
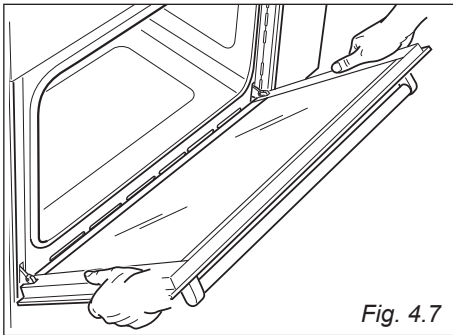
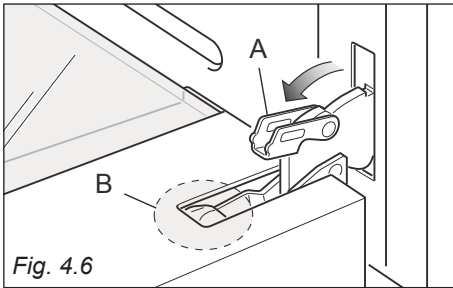
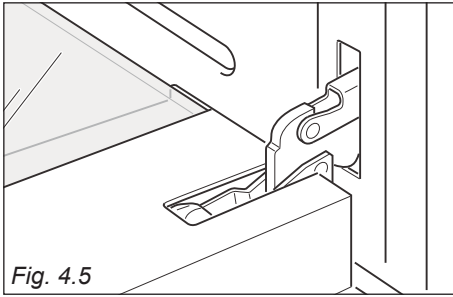

REMOVING THE OVEN DOOR

The oven door can easily be removed as follows:

- Open the door to the full extent (fig. 4.5).
- Open the lever "A" completely on the left and right hinges (fig. 4.6).
- Hold the door as shown in fig. 4.7.
- Gently close the door (fig. 4.8) until left and right hinge levers "A" are hooked to part "B" of the door (fig. 4.6).
- Withdraw the hinge hooks from their location following arrow "C" (fig. 4.9).
- Rest the door on a soft surface.

Important!

Always keep a safe distance from the door hinges, paying special attention to position of your hands.

If the door hinges are not correctly hooked, they could unhook and close suddenly and unexpectedly with risk of injury.

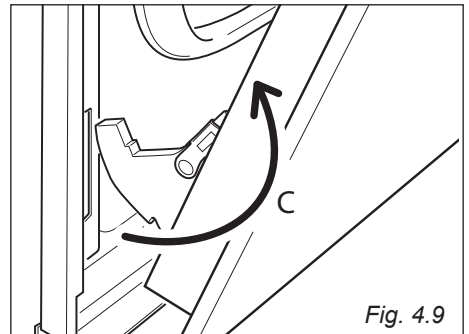
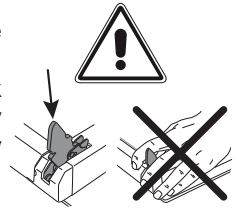

REFIT THE DOOR

1. Hold the door firmly (fig. 4.10).
2. Insert the hinge tongues into the slots, making sure that the groove drops into place as shown in the figure 4.11.
3. Open the door to its full extent.
4. Fully close the levers "A" on the left and right hinges, as shown in the figure 4.12.
5. Close the door and check that it is properly in place.

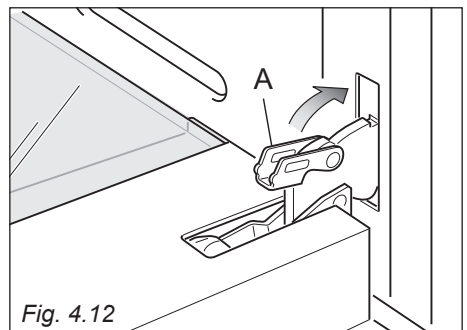
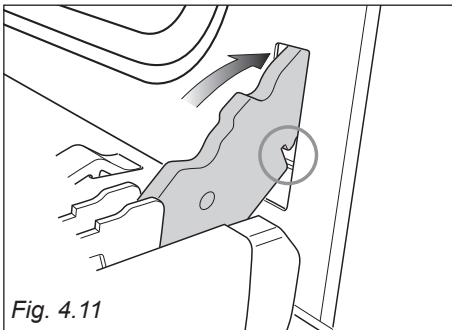
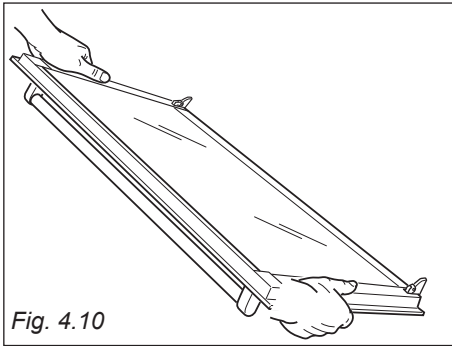



Cod. 1106532/GB - R0

GB

The manufacturer will not be responsible for any inaccuracy resulting from printing or transcript errors contained in this brochure. We reserve the right to carry out modifications to products as required, including the interests of consumption, without prejudice to the characteristics relating to safety or function.